



JAEA's Efforts for Regional Transparency in the Area of Nuclear Nonproliferation

Barbara HOFFHEINS, Yoko KAWAKUBO and Naoko INOUE

Department of Science and Technology for Nuclear Material Management

March 2014

本レポートは独立行政法人日本原子力研究開発機構が不定期に発行する成果報告書です。
本レポートの入手並びに著作権利用に関するお問い合わせは、下記あてにお問い合わせ下さい。
なお、本レポートの全文は日本原子力研究開発機構ホームページ (<http://www.jaea.go.jp>)
より発信されています。

独立行政法人日本原子力研究開発機構 研究技術情報部 研究技術情報課
〒319-1195 茨城県那珂郡東海村白方白根 2 番地 4
電話 029-282-6387, Fax 029-282-5920, E-mail:ird-support@jaea.go.jp

This report is issued irregularly by Japan Atomic Energy Agency.
Inquiries about availability and/or copyright of this report should be addressed to
Intellectual Resources Section, Intellectual Resources Department,
Japan Atomic Energy Agency.
2-4 Shirakata Shirane, Tokai-mura, Naka-gun, Ibaraki-ken 319-1195 Japan
Tel +81-29-282-6387, Fax +81-29-282-5920, E-mail:ird-support@jaea.go.jp

JAEA's Efforts for Regional Transparency in the Area of Nuclear Nonproliferation

Barbara HOFFHEINS, Yoko KAWAKUBO and Naoko INOUE

Department of Science and Technology for Nuclear Material Management
Japan Atomic Energy Agency
Tokai-mura, Naka-gun, Ibaraki-ken

(Received January 31, 2013)

The Japan Atomic Energy Agency (JAEA) has undertaken a joint R&D project with the US Department of Energy's National Nuclear Security Administration (DOE/NNSA) for the purposes of developing an Information Sharing Framework (ISF) for regional nonproliferation cooperation since July 2011. This project builds on nearly twenty years of technical cooperation between JAEA, its predecessor organizations and the DOE including the activities to define, develop and test transparency technologies and other multilateral efforts. The objective of current project is to design a viable information sharing process to support the goals of building confidence in the peaceful nature of regional nuclear programs. At the end of a two-year-effort, project partners, JAEA and Sandia National Laboratories (SNL), have defined the comprehensive requirements for an ISF that will ensure nonproliferation transparency success and sustainability. In October 2011, a parallel project with the similar title and objective was launched under the arrangement between the US DOE/NNSA and the Republic of Korea Ministry of Education, Science and Technology (MEST). Since then, JAEA, SNL, the Korea Institute for Nuclear Nonproliferation and Control (KINAC) and Korea Atomic Energy Institute (KAERI) have jointly carried out the project in a form of informal, multilateral cooperation. The project partners have identified needs and audience for ISF, and initiated the discussion to develop requirements for ISF through workshops, meetings, regular telephone conferences, etc. The activities include conducting a survey to identify stakeholders' needs and requirements for an ISF, launching a website to practice information sharing concepts, and presenting papers. This paper provides the historical context of the current project to establish ISF, and reports the progress to date and speculates on future directions.

Keywords: Nonproliferation, Transparency, Information Sharing, Regional Cooperation

原子力機構における地域核不拡散の透明性に関する取組み

日本原子力研究開発機構 核物質管理科学技術推進部

Barbara Hoffheims、川久保 陽子、井上 尚子

(2013年1月31日 受理)

日本原子力研究開発機構(JAEA)は、米国エネルギー省国家核安全保障局(DOE/NNSA)との保障措置・核不拡散技術協力取決めのもと、2011年7月よりサンディア国立研究所(SNL)と共同で「地域核不拡散協力のための情報共有フレームワーク(ISF: Information Sharing Framework)の構築」と題したプロジェクトを推進している。JAEA 及びその前身機関は、DOE/NNSA との協力により、20年近くに渡って透明性に関する概念設計、技術開発、協力活動、及びその他の多国間の取組み行ってきた。本プロジェクトはこれらの取組みを礎とし、アジア太平洋地域における原子力平和利用に対する信頼醸成を支援するために有効な情報共有プロセスを設計することを目的としている。約2年間で予定している本プロジェクトの終了時には、持続可能な形で核不拡散の透明性にかかる活動を実施できるよう、ISF の要求事項を開発することに主眼が置かれている。2011年10月には、DOE/NNSA と韓国教育科学技術省(MEST)の間の研究枠組み下でも、ISF 構築のための同様なプロジェクトが開始され、現在は JAEA、SNL、韓国核不拡散核物質管理院(KINAC)、韓国原子力研究所(KAERI)の4つの機関によって実施されている。本プロジェクトに関与する専門家は、これまで2回のワークショップ、各種会合、定期電話会議等を通じて、ISF に対するニーズや具体的なオーディエンスを特定し、要求事項の開発を行ってきた。また、ISF の潜在的ステークホルダーに対する調査、情報共有を実践するためのウェブサイトの構築、学会への論文投稿等も実施した。本報告書は透明性に関する歴史的背景を概観した上で、ISF 構築に向けた現行プロジェクトの位置付けを明らかにするとともに、地域核不拡散の透明性向上に寄与するための情報共有の在り方を論ずるものである。

Contents

1. Introduction & History 1

 1.1 Background 1

 1.2 Regional Nonproliferation Transparency Efforts 4

 1.2.1 ABACC and EURATOM..... 4

 1.2.2 APSN..... 5

 1.2.3 FNCA 6

 1.2.4 CSCAP 6

 1.2.5 Centers of Excellence (COE)..... 6

 1.2.6 Proposed Organizations 7

 1.3 Past Activities Related to Development of Transparency Concepts 8

 1.3.1 Action Sheets (AS) with DOE 8

 1.3.2 Transparency Workshops..... 12

2. Current Project: Project Action Sheet 16, Development of an Information Sharing Framework for Regional Nonproliferation Cooperation 15

 2.1 Background 15

 2.2 Accomplishments to Date 16

 2.2.1 PAS-16 and AS-26 Transparency Workshops 16

 2.2.2 Compelling Need for an Information Sharing Framework..... 16

 2.2.3 Project Plan & Execution..... 19

 2.2.4 Outreach Activities 21

 2.2.5 Model Framework 22

 2.2.6 Elements of an Information Sharing System 22

 2.3 ISF Architectures..... 34

3. Possible Outcomes 36

 3.1 ISF for Regional Nonproliferation Cooperation..... 36

 3.2 How the ISF can Support IAEA Safeguards 37

 3.3 How the ISF can Support Nuclear Security Cooperation 40

4. Future Steps 41

5. Conclusions 42

References 44

目 次

1. 序論及び背景.....	1
1.1 背景.....	1
1.2 地域における核不拡散透明性に関する試み.....	4
1.2.1 ブラジル・アルゼンチン核物質計量管理機関 (ABACC)と欧州委員会査察部門 (EURATOM).....	4
1.2.2 アジア太平洋保障措置ネットワーク(APSIN).....	5
1.2.3 アジア原子力協力フォーラム (FNCA).....	6
1.2.4 アジア太平洋安全保障協力会議 (CSCAP).....	6
1.2.5 センターオブエクセレンス (COE).....	6
1.2.6 現在提案されている機関.....	7
1.3 透明性概念開発に関連するこれまでの取組み.....	8
1.3.1 米国エネルギー省とのアクションシート (AS).....	8
1.3.2 透明性ワークショップ.....	12
2. 現在実施中のプロジェクト: プロジェクトアクションシート(PAS)16「地域核不拡散協力のための情報共有フレームワークの構築」.....	15
2.1 背景.....	15
2.2 これまでの成果.....	16
2.2.1 PAS-16 と AS-26 に基づく透明性ワークショップ.....	16
2.2.2 情報共有フレームワークの必要性.....	16
2.2.3 プロジェクトの計画と実施.....	19
2.2.4 アウトリーチ活動.....	21
2.2.5 モデルフレームワーク.....	22
2.2.6 情報共有システムの要素.....	22
2.3 ISF の構造.....	34
3. 期待される成果.....	36
3.1 地域核不拡散協力のための情報共有フレームワーク (ISF).....	36
3.2 国際原子力機関 (IAEA) 保障措置支援のための ISF.....	37
3.3 核セキュリティ協力のための ISF.....	40
4. 今後の展望.....	41
5. 結論.....	42
参考文献.....	44

1. Introduction & History

1.1 Background

Japan's policy of nonproliferation was officially established in 1955 with the Atomic Energy Basic Law that limits the use of nuclear energy to nonmilitary purposes. Japan continues to demonstrate and publicize its commitment to nonproliferation through many ministerial level venues and official actions including its early adoption of the Additional Protocol, implementation of integrated safeguards, and participation in unofficial venues such as Council for Security Cooperation in the Asia Pacific (CSCAP) and Asia Pacific Safeguards Network (APSN)¹⁾.

Likewise, JAEA and its predecessor organizations, Power Reactor and Nuclear Fuel Development Corporation (PNC) and Japan Nuclear Fuel Cycle Development Institute (JNC), have supported the national policy through research and development, State System of Accounting for and Control (SSAC) training especially for Asian countries, an annual international forum, and other meetings, workshops, civic interactions and publications. A recent activity has been to establish the JAEA's Integrated Support Center for Nuclear Nonproliferation and Nuclear Security (ISCN). Since 2011, ISCN has joined the growing number of organizations that provide nuclear security and safeguards training and technical assistance to help emerging nuclear energy countries develop the necessary human capital and institutional infrastructure. Other Asia Pacific states are undertaking similar training centers, called "Centers of Excellence" (COE) and ideally will work together to share their strengths, build human capacity in relevant nonproliferation infrastructure, and improve regional cooperation.

In keeping with the longstanding national policy of peaceful use of nuclear energy, JAEA and its predecessor organizations have studied and promoted concepts and tools to support multilateral and regional technical collaboration activities since 1995. Early projects examined the policy context of transparency and possible mechanisms to share information and demonstrate peaceful nuclear energy use to improve worldwide acceptance of nuclear energy. JAEA sponsored workshops, in conjunction with these projects, to widen the discussion among stakeholder organizations for the development of useful and practical transparency tools and activities. In particular, participation in the workshops and related meetings by KINAC and KAERI, the International Atomic Energy Agency (IAEA), US national laboratories, and representatives from other states in the Asia Pacific region has been beneficial for setting the stage for future regional endeavors. These activities have highlighted the important role of R&D and technical organizations to contribute to national policy goals through the practice of activities and development and validation of enabling tools that demonstrate and reinforce the national positions.

A key element of regional cooperation and collaboration is the practice of transparency. Transparency was defined as “a cooperative process of providing information to all interested parties so that they can independently assess the safety, security, and legitimate management of nuclear materials²⁾.” Transparency activities are important for building confidence among domestic audiences and neighboring states that national nuclear energy programs are strictly for peaceful use, and to strengthen cooperation between states for mutual benefit. Transparency is a voluntary activity that supplements the obligatory measures required by safeguards agreements, in order to provide additional assurances of the peaceful use of nuclear energy. These activities should be carried out to complement the IAEA verification activities that are conducted under bilateral agreements between the IAEA and the subject country. Ideally, they also serve to reinforce IAEA’s credibility and reduce its safeguards burden.

The need for *regional nonproliferation transparency* is obvious within the context of continued growth of new and existing nuclear energy infrastructures in Asia, and regional tensions about nuclear proliferation and security of nuclear materials³⁾. Moreover, the Fukushima accident raised safety concerns especially among Japan’s neighbors and demonstrated that nuclear accidents and their effects transcend national borders. Many experts and outcomes of recent international meetings continue to encourage multilateral information sharing especially for establishing and reinforcing nuclear safety, security, and safeguards programs, and strengthening international frameworks of cooperation in those areas. A number of regional transparency initiatives, such as the Asia Pacific Safeguards Network (APSN), and the Council for Security Cooperation in the Asia Pacific (CSCAP) study group, which seeks to “[Counter] the proliferation of weapons of mass destruction in the Asia Pacific,” are examples of unofficial efforts to increase nonproliferation understanding and cooperation among Asia Pacific neighbors^{4),5)}. The communiqué from the 2012 Nuclear Security Symposium in Seoul stressed the need for bilateral and multilateral cooperation to share best practices and build national capabilities⁶⁾. J. Carlson who attended the Symposium as a counselor of Nuclear Threat Initiative (NTI) further emphasizes in his article⁷⁾ that nuclear security accountability is a necessary element of transparency to assure the international community that a state is managing its nuclear materials responsibly. Greater regional nonproliferation transparency would also contribute to the IAEA’s efforts to understand and assess each state’s compliance with NPT agreements.

In Fig. 1.1, the relationship of the IAEA and its bilateral arrangements with individual states are shown on the left. The aim of regional nonproliferation transparency is to make communication and cooperation on nonproliferation matters

more effective, sustainable and beneficial to a regional community and at the same time support IAEA’s assessments of national nuclear programs.

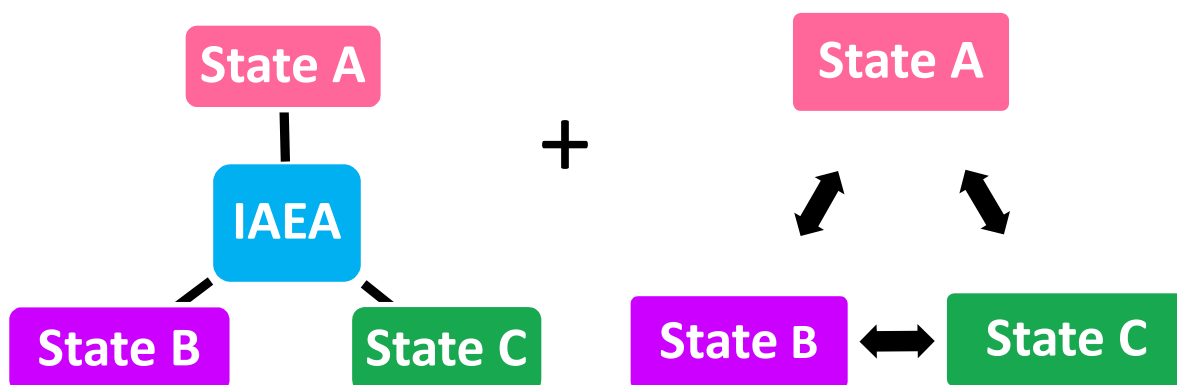

Fig. 1.1 Information sharing architecture - bilateral between IAEA and each member state/ multilateral among member states

In a conceptual model, the bilateral arrangements of the IAEA with each Member State (left side) are augmented by the addition of an arrangement that provides structure and mechanisms for states to exchange meaningful information with each other to increase the confidence in the peaceful nature of their nuclear energy programs (right side).

Transparency is understood to be an obvious element for enhancing bilateral and multilateral relationships, and is carried out as a matter of course in meetings, conferences, research programs, websites, etc. Although experts and meetings, such as the Nuclear Security Summit, recommend more information sharing between nuclear security and nonproliferation organizations, they don’t give specific guidance for immediate and practical implementation. J. Carlson also stresses that *appropriate mechanisms* for information sharing be used for demonstrating compliance with international norms and for offering support or requesting assistance⁷⁾. However, the experts merely state that information sharing should take place, but they don’t explain how to do it.

The ISF development is an attempt to define requirements for establishing tools and processes that further institutionalize transparency practices for greater overall effectiveness and efficiency of partner organizations and to enable trust building through sustained activities. Cooperative activities among JAEA, DOE/NNSA, KINAC, and KAERI have revealed insights that guide and support the efforts to specify the information sharing framework requirements and operation. The ISF should be designed to share meaningful information to inform, build trust, and resolve misconceptions. It

should avoid overloading information sharing partners with general, non-specific documents and data. But it is not a panacea for success. To instill a sustainable transparency culture, in addition to practical tools and processes, institutional commitment and practice over a long time are also required.

Anticipated benefits or practices of a transparency culture might include:

- Increased awareness and understanding of partners' nuclear programs and their goals and practices
- Learning and benefiting from each other's experiences
- Development and implementation of standard practices for safety, security, and safeguards
- Conducting cooperative projects for mutual benefit
- Providing a higher level of accountability that builds trust that nuclear programs are peaceful
- Stronger regional cooperation in nuclear nonproliferation areas might reduce the perceived risk of cooperation in other areas, and reduce barriers to establishing a stronger regional identity and influence
- Increased cooperation and sharing of information with partner states and the IAEA might help to ease IAEA's verification burden

1.2 Regional Nonproliferation Transparency Efforts

1.2.1 ABACC and EURATOM

Two formal regional structures provide useful ideas for information sharing in the Asia Pacific region, ABACC and EURATOM. Studies have analyzed their histories and progress in the context of pros and cons for establishing a formal Asia Pacific entity for nonproliferation cooperation.

The Argentina-Brazil Agency for Accounting and Control of Nuclear Materials (ABACC) was formally established in 1991⁸⁾. In 1994, ABACC, Argentina, Brazil and IAEA signed the quadripartite agreement for cooperation in safeguards implementation. ABACC objectives are to assure the international community of the peaceful use of nuclear energy, encourage openness between Brazil and Argentina, be a model system to encourage peaceful use in other international settings, and establish an environment of trust and collaboration. These objectives are underpinned with continuous improvements in technical competence and improvements to safeguards effectiveness and efficiency.

ABACC's activities are tailored to regional needs and characteristics, and include mutual inspections and information exchange that have been optimized to reduce the cost of safeguards implementation. ABACC is a partner with the IAEA as well as other Regional Systems of Accounting for and Control of Nuclear Material (RSACs) and State Systems of Accounting for and Control of Nuclear Material (SSACs). A current activity

engages with the IAEA to tailor safeguards systems and processes to support State Level Concept (SLC) implementation to improve qualitative analysis and to allow for more flexibility, and therefore more efficiency, in safeguards measures.

The European Atomic Energy Community (EURATOM) Treaty, entered into force in 1957, was established so that the member states could work cooperatively to develop successful and sustainable nuclear energy programs exclusively for peaceful use, and pool resources to support individual states in their pursuit of nuclear energy. Specific objectives include joint R&D programs, common training, application of uniform safety standards at nuclear installations, economic stability for nuclear power, and ensuring that all the member states have access to stable nuclear material sources. The EURATOM Treaty's articles outline measures to carry out these objectives, and include provisions for security and control of nuclear materials, an inspection program to verify compliance, and obligation to work with other countries and international organizations to promote peaceful use of nuclear energy⁹⁾. Transparency is therefore embedded in EURATOM's internal processes as well as in its communication and cooperative activities with other countries and international organizations.

The ABACC and EURATOM examples demonstrate that information sharing between the member states is an expected outcome of their arrangements. Many provisions in the agreements involve interactions between the member states and their citizens including R&D collaborations, mutual inspections of civilian nuclear facilities, establishing and certifying safety standards, and nuclear material transactions. These all certainly work to reduce regional tension and increase confidence in the safe and secure operation of nuclear programs. In contrast, most of the Asia Pacific programs are voluntary, informal and not strictly institutionalized. This is true of the Asia Nuclear Safety Network (ANSN) and the APSN. Experts at the 2012 Nuclear Security Summit lamented the lack of an Asia Pacific organization with a nuclear security focus. Some nascent steps in this direction include the Forum for Nuclear Cooperation in Asia (FNCA) 2012 workshop. Descriptions of some of the Asia Pacific programs and proposals follow.

1.2.2 APSN

Australia provided the impetus in 2006 to form an Asia Pacific safeguards organization through the Asia Pacific Economic Cooperation (APEC). As ideas for the organization evolved, interested parties agreed to form a voluntary, professional organization to focus on promotion of high standards for safeguards implementation. The APSN was established in 2009 as an informal professional network for member countries to improve their safeguards implementation and related technical expertise through cooperative activities including sharing experiences and best practices¹⁰⁾. Its role does

not include any regulatory or inspection functions. APSN's members include government or government-affiliated organizations associated with safeguards development and implementation from Australia, Canada, China, Indonesia, Japan, Malaysia, New Zealand, Philippines, Republic of Korea, Russia, Singapore, Thailand, United States and Vietnam. IAEA has observer status.

1.2.3 FNCA

Under the FNCA, an informal organization led by Japan's Ministry of Education, Culture, Sports, Science and Technology (MEXT) to cooperate in the peaceful use of nuclear technology in Asia¹¹⁾, participating countries include Australia, Bangladesh, China, Indonesia, Kazakhstan, Korea, Malaysia, Mongolia, Philippines, Thailand and Vietnam. In February 2012, FNCA sponsored a workshop under its nuclear Security and Safeguards Project to emphasize the importance of sharing implementation experiences for nuclear security and safeguards and building related human resources and infrastructure support¹²⁾. Workshop participants came from ministries with responsibilities for nuclear safety and safeguards and associated organizations established or planned for nuclear security and safeguards training and technical assistance.

1.2.4 CSCAP

The Council for Security Cooperation in the Asia Pacific (CSCAP) is an organization for scholars and government officials in their private capacities to exchange information related to regional security issues. One of CSCAP's study groups, "Countering the Proliferation of Weapons of Mass Destruction in the Asia Pacific"⁶⁾ has a nonproliferation focus that advocates more regional cooperation and information sharing, but does not operate at the working level itself. Beginning in 1998 CSCAP sponsored a website called "Nuclear Transparency in the Asia Pacific" for the purposes of sharing information, including environmental radiation levels at many nuclear facilities and virtual tours of facilities¹³⁾. SNL provided primary technical support, and JAEA supported this effort and contributed content to the website. This effort will be described in more detail in the section called, "Past Activities."

1.2.5 Centers of Excellence (COE)

Several states promised to establish COEs as part of their pledges during the 2010 Nuclear Security Summit to improve the security of nuclear materials worldwide. As mentioned, JAEA's ISCN is already operational. It provides safeguards and nuclear security training for domestic audiences and for participants from newcomer nuclear states, especially those in the Asia Pacific region. Another mission is R&D and technical

assistance for safeguards and nuclear security technology. Other COEs or similar organizations are planned or in operation not only in the Asia Pacific, but scattered across the globe¹⁴. The COEs present an excellent opportunity, if they choose to coordinate their efforts, to share best practices, experiences of implementation and a wealth of other non-sensitive information that can improve the overall quality and performance of each center and more efficiently and effectively accomplish their goals of building a network of nuclear security experts and organizations domestically and in emerging nuclear energy countries. At the 2012 Nuclear Security Summit, the countries of Algeria, Australia, Canada, Chile, Czech Republic, Germany, Hungary, Indonesia, Italy, Japan, Jordan, Kazakhstan, Republic of Korea, Lithuania, Malaysia, Mexico, Morocco, Netherlands, Pakistan, Philippines, Ukraine, United Arab Emirates, the United Kingdom, and the United States announced in a joint statement their intent to collaborate under the International Network for Nuclear Security Training and Support Centres (NSSCs) to strengthen human capital, provide technical support for instrumentation and the detection and response to nuclear security incidents. The IAEA will help to coordinate this network. The increased interaction and cooperation will also help to build confidence and trust in their respective nuclear programs.

1.2.6 Proposed Organizations

Several organizations for regional cooperation in peaceful nuclear energy use, similar in structure and purpose to EURATOM, have been proposed for the Asia Pacific region, but none of them have been realized. They include Asiatom (would not have included Canada, United States or Australia), Pacific Atomic Energy Community (PACATOM, including Australia, Canada and the United States) and Enhancing Nuclear Transparency for Confidence Building in Northeast Asia (ENTNEA). As with EURATOM, many transparency objectives would be incorporated in these formal structures.

(1) Asiatom

Asiatom was originally proposed as an Asian version of EURATOM focused on plutonium transparency, utilization and disposal¹⁵. Further elaboration of this idea included additional functions to promote regional nuclear energy cooperation, safety and nonproliferation objectives, such as regional cooperation and coordination of R&D, regional enrichment and reprocessing, regional fuel center(s) and waste disposal, and coordination, safety standards and protocols, information clearing and enhanced transparency for regional nuclear activities and activities to reduce IAEA's verification burden.

(2) PACATOM (Pacific Atomic Energy Community)

PACATOM was proposed by CSCAP's International Working Group on Confidence and Security Building Measures¹⁶ as a vehicle for reducing regional tension related to

nuclear energy concerns, and increasing regional cooperation in nuclear safety, security and safeguards through information sharing and coordination of regional activities, which could include regional safeguards and regional electric power grids.

(3)ENTNEA

In particular, ENTNEA concepts promoted by Nam and Shin¹⁷⁾ involve sharing information between states to expand and clarify what is known about areas of concern and thereby reduce tension. By doing so, states would hope to avoid responding to nonexistent threats and reduce uncertainties regarding environmental, safety and nonproliferation concerns about their nuclear facilities. Information sharing would include document or data exchanges and site visits based on specific issues of concern that hold value for the involved parties. The ENTNEA paper outlined several areas of possible cooperation, such as reactor safety, spent fuel safety and proliferation concerns, environmental impact of low-level waste solutions, and public acceptance of nuclear power. It recommended an informal, step-by-step approach tailored to information sharing needs for each identified issue. Initially, technical organizations in two or more states would identify joint research or academic exercises to benefit all participating parties. In undertaking these activities, information sharing processes, consisting of technical and/or administrative measures would be defined for project communication and completing project goals. Over time, the accumulation of experiences, lessons learned and refined procedures could lead to more forms of cooperation and possibly a more formal (ENTNEA) institution.

Cooperative activities among JAEA, DOE/NNSA, KINAC, and KAERI have included some steps similar to those prescribed by ENTNEA authors to identify specific information to be shared between interested parties to deepen understanding and work to build confidence about peaceful use of nuclear energy. Details of these activities will be described in a later section.

1.3 Past Activities Related to Development of Transparency Concepts

1.3.1 Action Sheets (AS) with DOE

JAEA and its predecessors have worked with US Department of Energy (DOE) national laboratories to explore technical mechanisms to enable regional nonproliferation transparency since 1995. Nine projects, called action sheets (AS), related to transparency have been initiated under the Cooperation Agreement, which was established in 1988 between PNC and DOE, Table 1.1¹⁸⁾. In addition, JAEA has hosted and co-hosted transparency workshops to open the discussion of transparency concepts and technology to a wider group of stakeholders and technical contributors.

Table 1.1 Action Sheets Related to Nuclear Transparency

AS #	Title	Dates	Partners
AS-20	Remote Monitoring System for Nonproliferation (Phase 1)	1995 1996	- PNC /SNL
AS-21	Joint Research on Transparency	1996 1997	- PNC/LANL
AS-33	Joyo Remote Monitoring System for Nonproliferation (Phase 2)	1998 1999	- JNC/SNL
AS-46	Application of Joyo Remote Monitoring System to Nuclear Nonproliferation and Transparency (Phase 3)	2000 2002	- JNC/SNL
AS-49	Cooperation in Nuclear Transparency (Phase 1)	2000 2003	- JNC/SNL (CSCAP)
AS-54	A Virtual Private Network	2002 2005	- JNC/SNL
AS-60	Cooperation in Nuclear Transparency (Phase 2)	2003 2005	- JNC/SNL (CSCAP)
AS-65	Development of Regional Collaboration, Transparency and Secure Data Communication for Nuclear Nonproliferation and Transparency	2004 2010	- JNC/SNL
PAS-16*	An Information-Sharing Framework for Regional Nonproliferation	2011 -present	JAEA/SNL

Under AS-21, PNC and Los Alamos National Laboratory (LANL) defined nonproliferation transparency concepts and notional activities for sharing information with other states and increasing bilateral communication with the IAEA with the ultimate goal of improving worldwide acceptance of nuclear energy. PNC and LANL performed independent studies and then exchanged views on the topics of : policy environment of transparency, development of transparency options, and technical options for transparency. Transparency was viewed to be instrumental for establishing acceptance of nuclear energy by addressing safety and nonproliferation concerns. Taking these extra steps beyond IAEA requirements should promote a higher level of trust. PNC and LANL agreed that criteria for applying transparency measures would require balancing the anticipated gains in confidence against costs of applying measures to

*Action Sheet (AS) was renamed to Project Action Sheet (PAS) when the cooperation agreement between DOE and JAEA was updated and signed in 2006.

facilities. The team looked at where the greatest gains might be achieved, for example, facilities that handle or produce direct use material would tend to generate the most concern about proliferation. A list of candidate transparency measures included release of information, such as quantities and compositions of nuclear material feed stocks, products, storage and waste; site tours; remote monitoring of facility activities; environmental monitoring; satellite monitoring of nuclear material shipments between facilities; and independent inspections.

AS-20, AS-33, AS-46, and AS-54 demonstrated and matured remote monitoring systems for safeguards and transparency applications using facilities at the PNC Experimental Fast Reactor 'Joyo' as test beds. A succession of experts from Sandia National Laboratories (SNL) was assigned to work on-site at Joyo under the PNC (later JNC) International Fellowship Program in the Oarai Engineering Center. Remote monitoring for transparency applications initially consisted of an on-site monitoring system at Joyo and remote-site data review stations at Joyo and SNL linked through conventional phone lines (modems) in 1997. The on-site system comprised a data acquisition system, various sensors including gamma detectors, and a digital camera system to monitor spent fuel assemblies received at the spent fuel storage facility. Data review stations displayed and archived data. The system was later expanded to monitor the fresh fuel storage area at Joyo and perform data analysis. As remote monitoring evolved, modems were replaced by Ethernet, and then the internet, with the use of virtual private networks to increase information security. Digital camera-based surveillance systems and other sensors, including non-destructive assay instruments, also followed a maturation path. A schematic of the 2008 remote monitoring system is shown in Fig. 1.2. Under these projects, the feasibility of secure wireless communication within a facility was demonstrated as a way to minimize wiring installation costs. SNL led the development and demonstration of similar remote monitoring systems that linked KAERI and Idaho National Laboratory (INL) facilities to SNL. IAEA, which was also investigating remote monitoring during this time, worked with Joyo to install cables in 2007 for routine use of remote monitoring with its own video surveillance systems.

Under AS-49 and 60, SNL led efforts to support a regional nuclear transparency website for CSCAP, called "Nuclear Transparency in the Asia Pacific" to further encourage transparency efforts in the region [14]. JAEA sent an expert to SNL for eighteen months to support the project. Project participants included representatives from nuclear power, fuel cycle and research and regulatory institutions from Japan, South Korea, China, Russia, Taiwan, Canada, India, and the United States who shared nuclear data and information in compliance with their public release policies. The website posted environmental radiation data and graphs and that were harmonized for ease of cross-comparison and to help non-specialists understand their meaning. Japanese

utilities provided information about spent fuel storage and transport. A virtual tour of the US Waste Isolation Pilot Plant (WIPP) for storage of TRU waste demonstrated how technology can be used to visit a site without having to physically go there or risk radiation exposure. J. Olsen pointed in his paper²⁰⁾ which recommended activities to further nonproliferation and confidence building, that this website would serve as the beginning of a “convenient, one-stop shopping” access point for regional safety and operational data.

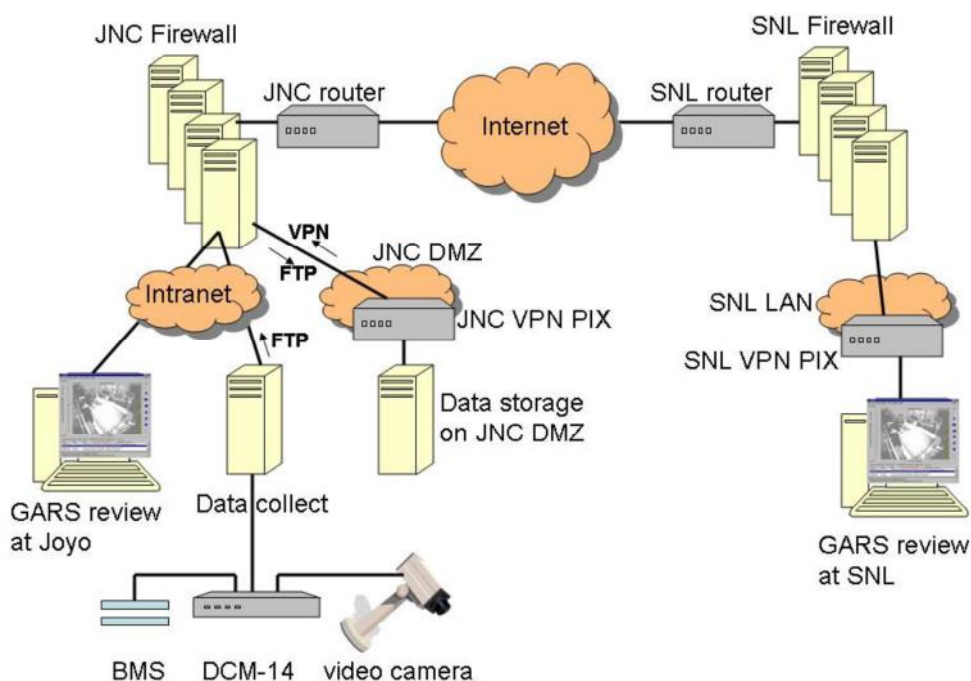

Fig.1.2 Schematic diagram of the JNC-SNL remote monitoring system¹⁹⁾

Under AS-65, JAEA continued development and demonstration of remote monitoring for transparency applications, published its own nonproliferation website and pursued face-to-face technical exchanges with SNL, KINAC and KAERI. These exchanges were useful for not only developing transparency concepts and plans, but also conducting transparency activities. One such meeting was the “1st Joint Technical Meeting on Regional Cooperative Nuclear Nonproliferation Transparency” held in 2009 in Daejeon, Korea, Fig. 1.3. In addition to previously mentioned topics, this meeting included site tours and discussions about technology, the need to engage young professionals to provide continuity, and other ways to perpetuate and strengthen the effectiveness of nonproliferation transparency activities. Other mechanisms of interaction under AS-65 included telephone and video conferences, Fig. 1.3.

The current effort, Project Action Sheet 16 (PAS-16), draws on the lessons learned from past action sheets and transparency workshops in conjunction with its work plan to establish the requirements of a regional information sharing framework for face-to-face and virtual (web-based) interaction. A critical achievement will be to develop concepts to expand from the proven two-way interactions to a multi-party framework by first demonstrating a Japan-Korea-US system/process designed to securely share information among partners. More details about the plans and activities of this action sheet are described by Kawakubo et al., and Mongiello, et al^{21), 22)}



Fig 1.3 (Left) Participants in the 1st Joint Technical Meeting on Regional Cooperative Nuclear Nonproliferation Transparency, held in Daejeon, Korea, 2009. (Right) Video conference between JAEA and KINAC.

1.3.2 Transparency Workshops

In coordination with action sheet activities, JAEA has sponsored or co-sponsored five transparency workshops (Table 1.2). KINAC, KAERI and IAEA, along with JAEA, DOE, SNL and other Japanese organizations took part in all of the workshops. The first three focused on the use of remote monitoring technologies for both IAEA safeguards applications and use by regional partners to build confidence in each other's peaceful, safe and secure use of nuclear energy. Remote monitoring systems and associated technologies, such as wireless communication, were demonstrated. Participants also discussed policy and other technical issues, including information security and its requirements.

The fourth workshop, co-sponsored by JAEA and the University of Tokyo GLOBAL Center of Excellence, expanded participation to include additional states (Vietnam, Australia, and Indonesia), the Pacific Forum of the Center for Strategic and International Studies (CSIS), the University of Tokyo, including students and industry, Canberra and Ludlum Measurements, Fig. 1.4. The workshop explored the intersection of transparency, technology and regional confidence building through a variety of

presentations and demonstrations. On the last day of the workshop, university students and young professionals exercised transparency concepts by designing hypothetical regional transparency networks for selected scenarios (domestic, bilateral and regional). Workshop participants raised many questions that demonstrated that constructing a meaningful transparency framework for the Asia Pacific region will require “time, perseverance and creativity,” but it is essential for continued success and peaceful nuclear energy production in the future.

Table 1.2 JAEA’s Transparency Workshops

#	Workshop Title	Participants	Topics	Year	Location
1	Transparency and Remote Monitoring	JNC, IAEA, ROK, US DOE, SNL, other Japan Orgs.	Promote remote monitoring as a transparency tool	2002	O-arai, Japan
2	Regional Transparency and Wireless Communication Workshop	JNC, IAEA, ROK, US DOE, SNL, Japan Orgs.	Use of remote monitoring in a regional setting	2003	Monju, Japan
3	Workshop on Regional Cooperation in Remote Monitoring for Transparency & Nonproliferation	JAEA, ROK, IAEA, US DOE, SNL, other Japan Orgs.	Share experiences and requirements of remote monitoring for regional cooperation & safeguards	2006	O-arai, Japan
4	Workshop on Transparency Technology for Nonproliferation Cooperation in the Asia Pacific	JAEA, U. Tokyo, SNL, IAEA, ROK, Vietnam, Australia, Indonesia, PACForum CSIS, Canberra, Ludlum, other Japan Orgs.	Intersection of transparency, technology and regional confidence building, developing next generation experts	2008	Tokyo, Japan
5	Transparency Workshop: Development of an Information Sharing Framework	JAEA, SNL, ROK (KAERI, KINAC), PNNL	Review of past efforts and accomplishments, establishing the need for information sharing	2011	Tokai, Japan

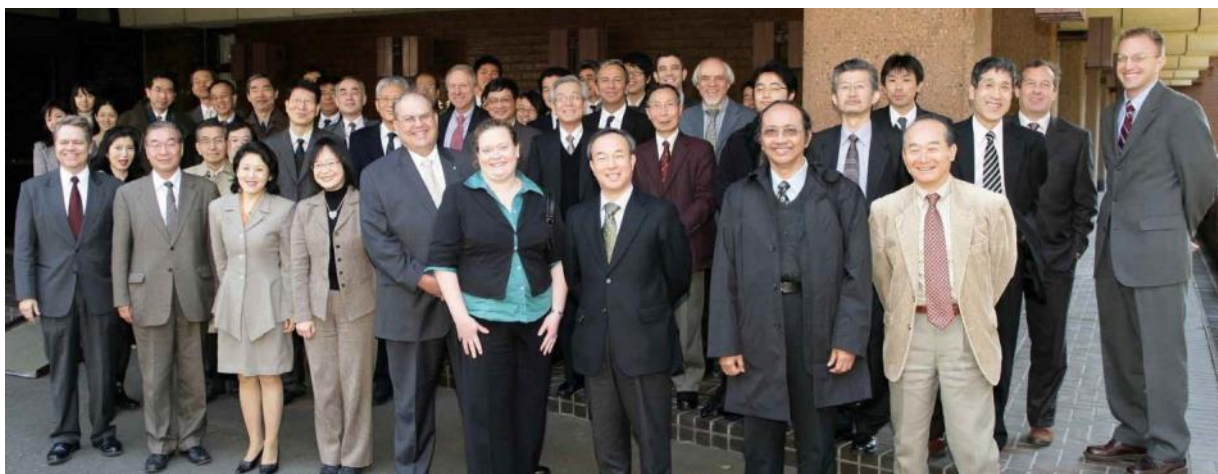

Fig. 1.4 Participants from the Workshop on Transparency Technology for Nonproliferation Cooperation in the Asia Pacific (2008)

The fifth transparency workshop, conducted in 2011 as an activity of PAS-16 and the DOE/NNSA - MEST Action Sheet 26, focused on establishing the need for an information sharing framework. Workshop participants included JAEA, SNL, KINAC, KAERI, IAEA and Pacific Northwest National Laboratory (PNNL). The discussions reviewed the progress to date under previous action sheets, related workshops and other activities. The workshop also addressed questions aimed at establishing and understanding the need for an information framework for nonproliferation cooperation in the Asia Pacific. It concluded that in the context of rapid regional changes and anticipated nuclear power growth, coupled with ongoing concerns about proliferation and safety, a transparency framework that complements and reinforces the IAEA's mission and builds confidence among regional partners is necessary. The details describe in section 2.2.1, 2.2.2 and 2.2.3.

After all of these efforts, workers continued to refine and expand ideas about transparency for nonproliferation purposes.

A side-benefit of not only the specific action sheet projects on transparency topics and regional cooperation but also the 100 or so other action sheet projects under the JAEA – US DOE cooperation agreement has been deepened technical and institutional ties between Japan and the United States. JAEA and the US DOE and its laboratories have been working together on joint R&D projects for about 30 years and celebrated 25 years of the formal cooperation agreement in 2013. The projects span many topics including development and testing of non-destructive assay instruments and data collection and analysis systems for nuclear material accountancy, chemical analysis of inspection samples, quality control of and provision of standard material for analysis.

Recently, the topics of these projects expanded to include nuclear forensics cooperation and study of accountancy methods to be applied to the damaged fuel at the Fukushima Daiichi Nuclear Power Plant. Associated with these projects have been many workshops and meetings, personnel exchanges, and cooperation with other partners including the IAEA, and organizations from Japan and other countries. Over the years, strong professional relationships have developed between Japanese and US participants in these action sheets. Another example of bilateral cooperation and information sharing has been the joint efforts under the United States-Japan Nuclear Security Working Group²³⁾. One can see that the accumulation of shared experience over many years leads to a deeper understanding of each state's nuclear capabilities and establishes foundation of trust that cannot be developed except through consistent practice over a long period.

2. Current Project: Project Action Sheet 16, Development of an Information Sharing Framework for Regional Nonproliferation Cooperation

2.1 Background

JAEA has undertaken a joint R&D project with US DOE/NNSA for the purposes of developing an information sharing framework (ISF) for regional nonproliferation cooperation. This project builds on nearly twenty years of technical cooperation between JAEA, its predecessor organizations and the DOE on the subject of transparency. The current project arose from the recognition that in spite of many activities to define, develop and test transparency technologies and cooperation, and other multilateral efforts, there is more work to be done to design a viable, information sharing process to support the goals of building confidence in the peaceful nature of regional nuclear programs. Furthermore, as pointed out by G. Baldwin in his paper²⁴⁾, nonproliferation transparency is an appealing idea that experts agree is necessary, but it is a complex problem to implement. This project seeks to develop requirements for an ISF that will ensure nonproliferation transparency success and sustainability.

Project Action Sheet 16 (PAS-16), titled "Development of an Information Sharing Framework for Regional Nonproliferation Cooperation" was signed on June 10, 2011 and July 1, 2011, respectively by authorities from JAEA and DOE. The term of this action sheet is two years. Project partners under this action sheet are JAEA Department of Science and Technology for Nuclear Material Management (STNM) and SNL.

The objective of PAS-16 is to design a system that enables the direct, transparent sharing of nonproliferation and safeguards-relevant information between the JAEA and selected other organizations in the Asia Pacific or other regions. The goal is to define the comprehensive requirements for multilateral information sharing, which will enable the design and development of a candidate system solution under a subsequent action sheet.

A separate action sheet, "Development of an Information Sharing Framework for

Regional Nonproliferation Cooperation,” AS-26, with the same objective as PAS-16 was signed between the Korean Ministry of Science and Technology (MEST) and DOE October 25, 2011. The existence of the two action sheets allows for an informal multilateral cooperation among Japan, Korea, and the United States. PAS-16 and AS-26 project partners include staff from JAEA, KINAC, KAERI and SNL.

2.2 Accomplishments to Date

The project partners have initiated many activities and studies to work towards the PAS-16 and AS-26 goals. The following sections describe those efforts.

2.2.1 PAS-16 and AS-26 Transparency Workshops

A transparency workshop was held December 2011 to establish the starting point for the development of the information sharing network. Workshop participants were from JAEA – STNM and ISCN, MEXT, KINAC, KAERI, SNL, Pacific Northwest National Laboratory (PNNL), IAEA and one observer from Thailand. The objectives were to review past action sheet achievements and related activities, update one another with the status of organizations and discuss questions aimed at confirming and establish the need for an information sharing framework. Presentations from JAEA STNM and ISCN, KINAC, KAERI and SNL reported on current organizational structures, missions, activities, and as well as past efforts related to transparency. A summary of the workshop was prepared.

A second transparency workshop was hosted by KINAC and conducted December 2012 in Daejeon, Korea. The objectives of this workshop were to use the results of interviews and an online survey to capture information sharing practices and needs to develop the requirements of the information sharing framework, and discuss next steps. Participants discussed the status of activities, lessons learned, types of information to share, methods of sharing information, and developed a final report and demonstration plan for the next phase of the project. The workshop summary report captured the discussions, recommendations, and next steps.

2.2.2 Compelling Need for an Information Sharing Framework

A significant portion of the December 2011 workshop was devoted to discussions about the need for transparency in the Asia Pacific region. Workshop organizers developed a list of questions to guide this discussion and in the progress of the discussion, new questions were raised. The original questions are listed below.

- Why is transparency important to the Asia Pacific region?
- After all of the Action Sheets, workshops, meetings, demonstrations etc., is transparency actually being carried out in the Asia Pacific region? If not, why not?
- Has a compelling need for information sharing been established?
- Who are the stakeholders and what are their concerns?

- What types of information would be considered useful to share?
- Should the information sharing framework be strictly tied to safeguards-relevant information, or should it expand into areas such as radiation exposure, safety of nuclear facilities, transportation safety, or safety of spent fuel?
- Example: Prior collaboration between JAEA and SNL included posting near-real-time airborne radiation data to a website.
- If improving communication methods between regional participants within the framework were an objective, how could it be achieved?
- Examples: Websites/Sharepoint, regular meetings, conference calls, formal structures, formal agreements.
- What types of technology could be used to help facilitate transparency in the Asia Pacific region?
- What would be necessary for someone to be able to trust the information that is provided transparently?
- Does released information need to be controlled in some way?
- How long is it available?
- How can information be recalled in necessary?
- How do we assess the value of sharing information and measure improvements in efficiency and effectiveness?

The workshop time frame was not long enough to attempt to answer all of these questions. In fact, additional questions were added to the preceding list. However, the questions became a starting point for establishing the need for an ISF and for use to frame and guide its design.

Workshop participants agreed that transparency is extremely important in the Asia Pacific region, not only in the aftermath of the Fukushima Daiichi Nuclear Power Plant (NPP) accident of March 2011, but also because of the anticipated regional expansion of nuclear energy. Nuclear nonproliferation, security and safety are all important elements of a nuclear transparency process that can promote public acceptance of nuclear energy, provide additional assurances, alleviate regional tensions, and reinforce IAEA safeguards.

Without a formal regional safeguards organization such as EURATOM or the ABACC, in which transparency is institutionalized, it is important to remember to include transparency activities in Asia Pacific nonproliferation interactions. In some cases, organizations have been established for the purpose of sharing information and mutual benefit, such as APSN and FNCA described earlier.

Although regional transparency initiatives are increasing, more could be done. Bilateral cooperation between Japan, Korea and the United States is strong, yet multilateral approaches could leverage these efforts to a greater degree. Action sheets

PAS-16 and AS-26 seek to implement such approaches.

The compelling reason that justifies establishing an ISF is not only supported through historical events, analysis of the current situation and common sense, but continues to be reinforced through a number of recommendations and outcomes from recent, non-related meetings and reports.

J. Carlson states in the article about new verification challenges for the IAEA²⁵⁾ that “the most serious of these is ensuring the capability to detect undeclared nuclear activities. Other safeguards challenges include: the potential spread of proliferation-sensitive technologies (enrichment and reprocessing) to further states; the implications of new fuel cycle technologies; and an ever-increasing workload.” Among his recommendations are those that advocate more transparency and confidence-building measures such as regional cooperation on nuclear programs, a freer flow of information between states than is currently allowed under IAEA rules and more mutual or regional inspections.

The Seoul 2012 Nuclear Security Summit Communiqué in addition to emphasizing states’ responsibilities to manage effective nuclear security in their own countries stressed the importance of promoting nuclear security objectives through regional and international cooperation⁶⁾. It encouraged all stakeholders including government, industry, academia, institutes and civil society to fully commit to security and effective communication and coordination of activities. IAEA’s nuclear security role includes promotion of networking, sharing experiences, and lessons learned. States should share best practices, bilateral and multilateral efforts to build national capabilities. Public diplomacy and outreach efforts are needed to inform the public of activities and actions taken to reduce the threats to nuclear security.

A. Heyes reviewed¹⁴⁾ the purpose and missions of organizations known as “Centers of Excellence” that were promised by many states at the 2010 Nuclear Security Summit for the development of capacity for nuclear security through technology development and training. Many of these centers are intended for operation in the Asia Pacific region to increase the cadre of nuclear security experts. Some of these centers are now operational, while many are still in the planning stages. The author recommended that these centers coordinate carefully with each other for mutual benefit to optimize efficiency and effectiveness, ensure standard and high quality practices and minimize unnecessary duplication of activities.

It was also recommended by T. Kassenova²⁶⁾ as to “Establish a clearing house for regional expertise sharing and assistance. Regional security will suffer if countries lack the resources and expertise to implement proliferation controls consistently. A regional forum could collect region-specific information so countries can benefit from each other’s expertise.” for nonproliferation of weapons of mass destruction in the Asia-Pacific region.

The above recommendations and many others further support the compelling need for an ISF and, in some cases, specifically advocate regional efforts for the Asia Pacific, but they do not offer *how* to do it. The ISF developed through PAS-16 and AS-26 will develop and test the methodology to make the ISF practical and useful for accomplishing regional nonproliferation cooperation goals.

2.2.3 Project Plan & Execution

The December 2011 workshop report listed several next steps, which became the basis for the project plan. These next steps are listed with a short summary of their status.

Short term (December 2011 through December 2012)

- Finalizing the workshop final report
 - The workshop report was finalized in December 2011.
- Establishing project and document communication plan
 - Status. The project team agreed to hold telephone conferences on a monthly basis. This has been valuable for raising questions and clarifying issues to make progress. Telephone conferences were established in February 2012 and have been continued on a roughly monthly basis. Face-to-face meetings were held during the 2012 INMM meeting in July, at KINAC's 2012 International Nuclear Non-proliferation and Security Symposium in September 2012, and with JAEA and SNL in Albuquerque in October 2012 with KINAC and other JAEA partners by teleconference.
- Identify specific information to share by virtual or face-to-face means
 - Status. The project team drafted and commented on a list of possible information to share as an initial exercise to develop the scope and requirements of the ISF. A further elaboration of information sharing needs will be collected by surveying stakeholders from various organizations about their information needs.
- Determine standards and criteria of information to be shared
 - Status. The survey activity to gather stakeholder information needs, described above, was used as a basis to identify information requirements and standards.
- Plan to submit and present papers at the 2012 Institute for Nuclear Material Management (INMM) annual meeting
 - Status. Project team members from SNL and JAEA prepared and presented papers at the 2012 INMM meeting in a SNL organized session called, "Transparency and Evaluation." The project team submitted and presented four papers concerning the rationale for establishing a transparency program, background, modes of information sharing, and overall project scheme. These papers were:
 - "Structuring the Nuclear Nonproliferation Transparency Problem," G. Baldwin and R. Mongiello

- “Development of an Information Sharing Framework: Efforts at Regional Transparency in the Asia Pacific,” R. Mongiello, G. Baldwin, B. Hoffheins, Y. Kawakubo, and N. Inoue
 - “Development of an information Sharing Framework: Communication Strategies,” Y. Kawakubo, B. Hoffheins, N. Inoue, R. Mongiello, and G. Baldwin
 - “Overview of Japan Atomic Energy Agency’s Regional Transparency Efforts,” B. Hoffheins, Y. Kawakubo, N. Inoue, R. Mongiello, and G. Baldwin
- a side meeting on the occasion of 2012 INMM Annual Meeting
 - Project team members from SNL, KINAC, KAERI, and JAEA met at the 2012 INMM annual meeting to discuss and plan project goals and activities.
- Update JAEA website to report regional transparency activities
 - Status. The project team discussed updating the JAEA website; however, this activity was put on hold. Alternatively, SNL launched a website called, “Nuclear Nonproliferation Transparency in the Asia Pacific” to deposit project documents and related information. This website might also become a communication vehicle for the ISF. More details about this website will be described later.
- Plan a follow on workshop
 - Status: The project team planned to hold a workshop in December 2012 in Korea. The focus of this workshop was to review progress, study the interview results to further refine ISF requirements and plan a demonstration test to be conducted in phase 2 of the project.

Medium Term (January 2013 through January 2014)

Note: This report was prepared in the autumn of 2012 and thus predates actions planned in the following steps.

- Establish conditions and requirements for sharing nonproliferation information focused on safeguards
- Invite other stakeholders, as necessary, to factor into Track I and Track III perspectives

Potential Long-term (efforts beyond 2014)

- Continue to refine information sharing mechanisms for regional cooperation
- Promote and demonstrate the benefits of regional transparency cooperation to those who are outside the cooperation

2.2.4 Outreach Activities

In addition to 2012 INMM presentations about PAS-16 and AS-26 activities, other outreach activities took place or were planned.

KINAC included a nuclear transparency topic in its “4th International Nuclear Non-proliferation and Security Symposium” on September 7, 2012, in Seoul. Presentations and discussions addressed ways to enhance transparency for the goal of building mutual trust in nuclear energy programs. Two presentations described the conceptual ideas and work in progress of AS-26 and PAS-16,

- “Information Sharing Framework: Efforts at Nonproliferation Transparency in Asia Pacific,” R. Mongiello.
- “Development of Information Sharing Framework for Nuclear Nonproliferation,” N. Inoue, B. Hoffheins, Y. Kawakubo

Other presentations in the session by representatives from APSN and ABACC discussed roles of regional networks.

- “Role of the Asia Pacific Safeguards Network (APSN) in Regional Transparency,” J. Kalish, Australian Safeguards and Non-Proliferation Office.
- “Role of ABACC in Regional Transparency,” Orpet Peixoto, ABACC, Brazil.

In a separate session about Centers of Excellence, participants reported and discussed the status and future plans of Centers of Excellence that are being established for nuclear security and safeguards training for building human capital and infrastructure.

JAEA will present an update of PAS-16 and AS-26 requirements development process at the IAEA’s “FR13 Conference on Fast Reactors on Related Fuel Cycles,” in March 2013. The abstract title is, “International Conference on Fast Reactors and Related Fuel Cycles: Safe Technologies and Sustainable Scenarios (FR13)”, Y. Kawakubo, et al., March 4 – 7, 2013, Paris.

PAS-16 and AS-26 partners are also planning a special session for the 2013 INMM Annual Meeting, tentatively titled, “Technology-Based Regional Nuclear Nonproliferation Cooperation – Benefits, Challenges and Opportunities,” which will report project activities and solicit views of experts involved in regional cooperation, transparency, and other related efforts.

2.2.5 Model Framework

In consideration of how to begin the development of requirements for the ISF, the project team agreed to develop a *model* ISF to test concepts. The information sharing partners of the model ISF consist principally of groups or individuals affiliated with AS-26 and PAS-16 partner organizations of SNL, KINAC, KAERI, and JAEA. Information to be shared in the model ISF will be limited to selected examples to make it easier to implement and test concepts, practice information sharing, and analyze results. Draft requirements for the model ISF were developed from existing and desired information sharing experiences of some of the organizations inside the AS-26 and PAS-16 partner organizations of JAEA, KINAC, KAERI, and SNL. The requirements development process is discussed in more detail in the next section.

2.2.6 Elements of an Information Sharing System

The elements of an ISF include partners and/or stakeholders, requirements, information to be shared, communication modes (mechanisms for sharing information) and measurement of effectiveness. All of these areas are important and must be well-integrated for the ISF to be effective.

(1) Stakeholders

The definition used for transparency discusses “interested parties” that are able to independently assess “the safety, security, and legitimate management of nuclear materials.” The “interested parties” are the stakeholders. Stakeholders are the people or organizations that are affected or can affect the actions of an organization. In a regional nonproliferation information sharing scheme, the stakeholders that immediately come to mind are the regional states and their organizations for implementing and managing nuclear energy programs, including government ministries and agencies, R&D organizations, industry, academia, etc. The IAEA would be a key stakeholder especially for safeguards information and as a focal point for nuclear security best practices and standards.

In the current project, JAEA analyzed stakeholders for JAEA nonproliferation and nuclear security missions. Stakeholders were characterized as Track I, II, or III and are described below.

Track I includes government officials acting in official capacities. They formulate the national policies for their mission areas and make decisions about the sensitivity of information and whether or not it is in the national interest to share it and with whom it can be shared. IAEA and other treaty-based international organizations are in this group. Information sharing must be consistent with the policies and rules of the relevant government ministries and organizations.

Track II includes non-government agencies, such as World Institute for Nuclear Security (WINS), Nuclear Threat Initiative (NTI). R&D and technical organizations that support and implement national objectives such as JAEA, SNL, KAERI, and COEs are Track II organizations. Academia and industry, depending on the situation, may be Track II or Track III.

Non-governmental agencies serve many functions. NTI provides a forum for experts who analyze information and assess the status of nuclear programs and the impact to the geopolitical situation. The APSN, consisting of representatives from ministries and organizations responsible for safeguards implementation in their respective countries, is a forum to share experiences and assistance to improve the effectiveness and efficiency of safeguards implementation. Experts point out that there is no nuclear security counterpart of APSN for nuclear security cooperation in the Asia Pacific, and therefore there is opportunity to build an ISF for that purpose.

Nuclear and related industries with safeguards and nuclear security roles might also benefit from and share in information exchanges. Industries that are directly involved in activities such as nuclear material processing or nuclear power will want to make sure proprietary information is protected; however, information exchange especially with counterparts in other countries could be beneficial. The World Nuclear Organization (WNO) already provides mechanisms for nuclear industries to interact and share information about the nuclear industry and its technologies. Nonproliferation topics are not part of WNO's core focus, although some nonproliferation information is shared on its website: <http://www.world-nuclear.org/>.

Academia can play many important roles in developing and testing new nonproliferation technologies, which advance the state of the art and provide opportunities for students to learn more about the safeguards and nuclear security and build their careers in these areas. Academia is often involved as a research partner with technical organizations. It is important for academia performing nuclear-related research to be aware of related national policies.

Track III consists of the public, media, business/industry, and activist organizations. These organizations should also have access to as much information as possible to allow them to understand how nuclear programs affect their lives, communities, and the standing of their country in the world. These groups also provide information that technical and policy organizations do not concern themselves with on a regular basis and they can be powerful persuaders for changes in policy. This can be good or bad depending on the observer's point of view. If these stakeholders feel threatened in any way by nuclear energy programs, they will likely voice the concern by many mechanisms including those with a high probability of being observed and heard, such as public demonstrations or advertisements in print or video media. It is important for the

Track I and II organizations to provide information in a form that is comprehensible and usable by Track III groups that might not have technical and policy backgrounds. Furthermore, Track III should be allowed to express their concerns and participate with Tracks I and II in appropriate settings to realize solutions to provide the best outcomes.

Under a model ISF to be developed by PAS-16 and AS-26, stakeholder groups were limited to selected action sheet partner groups and the IAEA. This was done to simplify the development, testing and evaluation of the model framework. In the model ISF, JAEA's, SNL's, KAERI's and KINAC's groups with safeguards and/or nuclear security functions are the main information sharing partners. IAEA will be an observer. Other Track I or Track III stakeholders will not be directly included.

(2) Information to be Shared

JAEA, SNL, and KINAC have held several discussions about what information would be useful to share. A table of possible information to share was drafted for brainstorming purposes. Important first considerations included what the anticipated benefit will be, followed by the information content, format, sharing mechanism, information provider and receiver, and any restrictions or caveats.

A number of benefits could be realized: demonstrate accountability to nonproliferation standards, gain a better understanding of the supplier's nuclear power program, learn from the suppliers' experiences, training, cooperative R&D, and so on. Conventional wisdom would say that practicing these information exchanges increases trust and confidence in the peaceful use of nuclear energy among participating countries. Notably, bilateral cooperation in the area of nuclear safeguards R&D between the US DOE and JAEA for over twenty years has produced many benefits for both partners and the participating organizations. Likewise, a similar bilateral cooperation between the US DOE and Korean authorities responsible for safeguards implementation and R&D has produced many benefits and continues to do so. Both collaborations have been conducted with the IAEA as a key stakeholder to ensure good coordination with international safeguards implementation. Furthermore, the show of good will in cooperating together in the R&D projects has demonstrated transparency on the part of each of the countries that can also be observed by a wider audience of non-partner countries and organizations.

Careful consideration should be taken by both information suppliers and receivers to identify the kind of information to share, its format, how it will be used, and other features. Furthermore, simply disseminating information for the sake of disclosure is not necessarily helpful because the information content and format might not be useable or useful. Overloading the receiver with too much general, non-specific information might require laborious in-depth analysis to satisfy concerns and questions about a particular

topic.

The information to be shared should be tied to specific concerns of either or both the information supplier and receiver and contribute to reducing them. In many cases, the information may be very specific and targeted only for one receiver.

We predict that in routine operation, more of the information exchange of an ISF is likely to be between functionally similar groups. There is a natural alignment of information sharing organizations, for example, KINAC's SSAC function is similar to that of Japan's Nuclear Material Control Center (NMCC), so sharing best practices and inspection experiences should be of interest and of value to both organizations. This "self-alignment" of various organizations will likely be reflected in the structure, requirements and operation of the ISF. In addition, the ISF might be adopted by organizations that are interested in only sharing information in a specific area, such as APSN or the COEs.

Discussions about identifying information to share will likely touch on topics of proprietary and national security information. The ISF requirements would not press organizations to share kind of information; however, it would make sense for organizations to periodically review information it protects to determine whether the original purposes and needs of protecting the information are still valid. Barriers to information sharing are to be expected for ISFs implemented in a multilateral setting. Alternatively, some information issues have been discussed and resolved with IAEA in bilateral agreements with states for safeguards approaches for various facilities, and these precedents might serve as guides for multilateral sharing. Some experts claim that information regarding nuclear security practices cannot be shared for national security reasons, although others point out that best practices and many aspects of lessons learned are not sensitive and would be useful to discuss. As information sharing partners become more familiar with the information sharing process and the level of confidence increases, it should be possible to widen the range and content of the information shared.

Sharing safeguards accountancy information could have the benefit of raising confidence in a state's material accountancy practices and compliance with its NPT obligations. Examples include safeguards implementation experiences that have been reported in published papers and in professional meetings, such as INMM. Actual material accountancy data, if agreed to by IAEA and the state, might be conveyed in a closed door meeting between two or more states. IAEA's safeguards conclusions, extracted with permission by the state and IAEA from IAEA's Safeguards Implementation Report (SIR) might also be used to elevate trust. States could post schedules, frequency, and types of IAEA's physical inventory verification (PIV) activities on websites and indicate completion of planned activities.

Korea and Japan are both pursuing experimental nuclear fuel cycle projects.

Korea and Japan could exchange available information about facility design and safeguards practices to deepen understanding and reduce concerns. Korea has already conducted tours of its experimental pyroprocessing project, which have included Japanese participants. In order for JAEA and KAERI to discuss on broader topics, the organizational framework should be reviewed. This brings up a challenge to some information sharing.

Some information sharing has occurred between KINAC, KAERI, JAEA and SNL during the course of some of their bilateral R&D projects with the US DOE through their respective cooperation agreements. The current project is an example of that. The December 2011 workshop agenda included briefings by KINAC, KAERI, JAEA and SNL about the status and missions of each organization. Professional meetings, such as INMM, offer a forum for information sharing on a general level. The possibility of attending each other's INMM chapter meetings would offer a different view of activities in each country. Another possible venue for information sharing would be through the IAEA's Member State Support Program (MSSP), in which the U.S.A., Japan and Korea all participate. Under this structure, it is also possible for JAEA and KINAC/KAERI to participate in joint support program tasks.

JAEA and KINAC both have COEs that are or will be providing training domestically and for many Asia Pacific states that want to build their safeguards and nuclear security capacities. SNL also provides training in these areas. Sharing information on the types and amount of training that each organization is planning in other countries would be a good first step toward coordinating training for the best use of each COE and to provide standardized and consistent training to all participants. These actions would also be beneficial for each COE for optimal use of their budgets.

Both Japan's and Korea's SSACs and COEs participate in APSN. The APSN has recently undertaken a survey among its members to learn what their training needs and capabilities are²⁷⁾. JAEA's ISCN has also conducted a needs survey of the Asian countries in which it conducts training.

Information about the resolution of the Fukushima nuclear accident of March 2011 for safeguards, safety and security is of high interest to Japan's neighbors as well as the rest of the international community. How Japan handles and shares information in this area will be important for the future of its credibility in nuclear matters. Japan must also share information to reassure the public and international community that all areas of concern have been appropriately analyzed and measures have been taken to correct past mistakes and minimized future risks. JAEA has been involved with developing the materials accountancy systems and approach for the damaged fuel at Fukushima Daiichi NPP. KINAC and KAERI as well as other similar organizations in neighboring states may be very interested in learning whatever they can about the situation.

(3) ISF Requirements Development

JAEA team members constructed a draft procedure for establishing information sharing requirements independently of the survey process. The main points of Baldwin's paper²⁴⁾ were used as a guide to develop the procedure of what information to share and the parameters of information sharing. The continuous improvement cycle of "Plan, Do, Check, and Adjust" was adopted to guide the requirements planning, execution, and evaluation processes. In an iterative step, SNL further refined this rough draft to provide specific details. Both draft documents might be viewed as essential elements of a single requirements document, with the SNL portion used for routine and established information sharing situations and the JAEA procedure for determining how to share information for new topic areas.

These documents were discussed in the second project workshop in December 2012. During the workshop, ISF requirements for a specific information topic area were drafted as an exercise to further examine, test and define the necessary elements of the ISF requirements.

The content of the JAEA draft information sharing requirements procedure is shown below.

Draft Requirements (JAEA)

1. Define the objective of the information to be shared.
 - a. What is the specific concern?
 - b. How will the receiver use the information? What judgment does the receiver want to make?
2. Characterize the audience. (For the purposes of demonstrating a model framework, the organizations with responsibilities related to nuclear safeguards and security in JAEA, KINAC, KAERI, and SNL are the audience. IAEA is a key stakeholder.)
3. Define the scope. (For the purposes of demonstrating a model framework, nuclear safeguards and security are the defined scope.)
4. Select the content
 - a. Assess the context
 - i. What information is shared, how much, and how often.
 - ii. What other factors have to be considered in order to share the information? For example, is permission from a higher authority required? Is a new or modified MOU required?
 - b. Define and determine the requirements for information quality (information authenticity and credibility)
5. Infrastructure
 - a. What tools are required for sharing the information; how will the information be shared? How will the tools be managed and maintained?

- b. What level of information security is necessary? How will the appropriate level of security be achieved?
- 6. Establish metrics - Necessary to ensure sustainability
 - a. What determines if the information sharing was successful?
 - b. Feedback and review by everyone in the process
 - i. Did the information sharing meet expectations?
 - ii. What parts of the process can be improved?

The above draft requirements are a general approach to developing an ISF and were not based on existing information sharing practices among model ISF stakeholders or their information needs. A survey was later conducted among the stakeholders to gather this information.

(4) Survey of Model Framework Stakeholders

With respect to stakeholders in the model framework, it was important to learn their interests and information sharing priorities. Do organizations already share information? What are the existing information pathways? How do they share, what kind of information do they share and how effective is it? What additional information do stakeholders wish to receive? The survey was designed to gather more specific information from individuals and or groups within the PAS-16 and AS-26 partner organizations about information that would be beneficial to share. The survey results will be used to better understand the parameters of the ISF design and to develop its requirements.

Information stakeholders play one or two roles: receiver of information, supplier of information. The project team developed questions for a survey of information receivers and suppliers among SNL's, KINAC's, KAERI's and JAEA's safeguards, nuclear security, and nuclear facility groups. The survey asks respondents to identify the types of nonproliferation-related information that their organizations share with counterparts in other countries. The survey also asks about what kind of information the respondents receive and what kinds of additional information would be useful to share or receive. Questionnaire responses will be further analyzed to refine the draft requirements documents. From these results, information sharing test cases will be selected for a demonstration as the next step of the ISF project. The information sharing demonstration outcomes would then be evaluated and lessons learned would be used to update ISF requirements. Furthermore, plans for expanding and implementing the ISF would also be formulated.

SNL Stakeholder Survey

SNL developed a web-based questionnaire with the interview questions and posted it to the "Nuclear Nonproliferation Transparency in the Asia Pacific" website.

SNL conducted its surveys using its web-based survey form. Three nonproliferation technical experts were asked to respond to the survey. Currently, these experts receive information about nuclear safeguards, nuclear security, physical protection, export controls, and international technical cooperation. They view this information to be moderately to highly important. They would like to receive information about nuclear safeguards and security best practices and nuclear laws, nuclear energy and waste management in the Asia Pacific regions, training requirements, types of facilities, facility design and nuclear material inventories by type or amount. Ideally they would like updates to this information on a six to twelve month basis though face-to-face means, such as workshops, conferences or training or web-based modes, such as websites or email, or through monthly teleconferences. Survey respondents also suggested activities such as identifying or developing collaborative analysis and training, and use of web-based exchanges before training to familiarize new trainees with materials. They cited concerns about misuse of information, loss of control of documents, protecting IT systems, and compliance with security policies.

The SNL interviewees reported some perceived deficiencies in the current practices. Although SNL staff members are receiving information about specific topics, they would like the frequency of interaction or receiving information to increase. They listed several additional topic areas of interest and new kinds of collaborative activities to develop and strengthen international relationships. They stated that information protection and security was important.

JAEA Stakeholder Survey

JAEA project team members interviewed staff members from their own organizations having safeguards and nuclear security missions (STNM and ISCN). Some of the interviews were conducted in person and other surveys were filled out after an in-person explanation of the survey. Among JAEA interviewees, most information sharing is conducted face-to-face with support from email and teleconferences. STNM staff members associated with PAS-16, have supplied organizational status information to SNL, KINCA, KAERI and IAEA under the PAS-16 activities. PAS-16 activities, such as workshops, meetings and teleconferences have also been a form of information exchange. Staff members from JAEA's Nuclear Forensics team have reported their current activities and received information from the U.S.A. about the nuclear forensics library project. More generally, STNM and ISCN share information through their joint R&D projects (action sheets) with US DOE laboratories in nuclear security and physical protection training, development of safeguards technologies and approaches, environmental sampling, etc. JAEA STMM also supports the Government of Japan in the US–Japan Nuclear Security Working Group (NSWG). JAEA STNM participates in the

Generation IV International Forum (GIF) Proliferation Resistance Physical Protection Working Group (PRPP WG) since its inception and routinely reports the status of nuclear fuel cycle facilities and activities of JAEA related to PRPP areas as a country report.

STNM hosts the annual international forum called “Nuclear Energy, Nonproliferation and Nuclear Security,” which is open to the public. Invited speakers from governments and technical organizations offer their personal views about the forum’s themes. The audience, which can consist of Track I, II, or III stakeholders, is invited to also ask questions and provide comments.

Possible future information sharing areas were identified. In the past, STNM worked closely with SNL to develop remote monitoring technologies to securely view live and recorded images of facility operations and storage areas. In the future, it might be useful to share camera images from selected facilities. In the short term, KINAC and JAEA agreed to share INMM chapter meeting agendas and will consider also sharing English versions of the agendas. To implement this may require an update to the JAEA-KAERI organizational framework.

To support capacity building in emerging nuclear countries, mostly from the Asian region, ISCN has delivered training for topic areas such as safeguards implementation, nuclear security, physical protection. In the course of developing and providing training, ISCN solicits training needs from trainee countries and learns about the status of and plans for their nuclear programs. It also works closely with SNL to mature its own training curriculum and practices. ISCN training is a rich source of information and includes information about Japan’s nuclear energy policies, practices, and lessons learned from additional protocol implementation. ISCN has shared some information about training areas and future plans with counterparts in KINAC and China and wishes to coordinate and cooperate more fully with other COEs in the future for increased effectiveness and efficiency.

The results from the JAEA survey indicate that information sharing is often necessary to complete work goals or to improve operations. Transparency is often a by-product of these activities. One notable exception is JAEA’s international forum, in which the primary objective is to publically discuss opinions and concerns about selected topic areas. Information sharing is also often associated with formal associations, for example, the JAEA-US DOE cooperation agreement. Most of information sharing reported by STNM has been of a bilateral nature with the US DOE or its labs. The ISCN recognized the need to work more closely with other COEs for mutual benefit. As mentioned, the IAEA has announced it will provide a coordinating role for COEs under the NSSC.

(5) Communication Modes

To support the key goals of confidence building, and transparency, exchange of information is essential. The JAEA project team classified information sharing mechanisms as “face-to-face” and “web-based” and reviewed and analyzed their characteristics²²⁾.

Face-to-face Communication

Face-to-face information sharing is the traditional communication method. People meet each other in professional meetings, training, workshops, through personnel exchanges, and in cooperative research projects. Conventional wisdom and experts maintain that in-person meetings have greater potential for developing stronger relationships that can be more effective for negotiation, and building consensus and trust [29, 30]. Part of the reason is because of the richer information content conveyed through body language and vocal dynamics. Another aspect is that on a basic level human beings need interaction with one another.

PAS-16 project partners pointed out that some information sharing is more effectively achieved through face-to-face meetings when the information contains some sensitive nature and it is hesitated to be shared online, when anecdotal stories and additional details can be shared at the same time and when the information receiver has the opportunity to ask questions and receive answers in real time. The direct experience of a facility tour, joint research project, training exercises or similar, offers benefits that include much richer information than merely reading and conversing electronically. Some specific activities to increase cohesion and cooperation in the Asia Pacific region would include joint training of SSAC inspectors²⁰⁾, joint training in use of nuclear security systems, and tours of R&D and NFC facilities.

There are many advantageous face-to-face activities for an ISF. The ability to be physically present in a meeting, facility tour, research activities, etc., gives a high level of authenticity to the experience, which directly correlates to a higher level of confidence in the ability to judge the credibility of the information exchange. However, the organizations’ budgets or schedules sometimes do not allow making face-to-face opportunities. In some cases, virtual information exchange through the teleconference or video conference could help.

Web-based Communication

Web-based information methods include videos, on-line training and seminars, online databases and reports, teleconferencing and email. Most of these methods can be used at any time and in any location as long as an internet connection is available. The

number of participants is usually not an issue and participants can join the interaction regardless of their location. Many web-based interactions do not require real-time participation by all partners. However, one disadvantage for online meetings or teleconferences is that it can be difficult to schedule convenient times to accommodate all participants' time zones.

Many of these web-based tools continue to improve. Analysts have developed a "media richness theory" that ranks electronic media in terms of the amount of information that can be effectively conveyed compared with face-to-face communication²⁸). The general order of effectiveness is video, telephone, email and computer documents.

In multilateral situations, ensuring information security and authentication are important. Web-based information exchanges systems should adhere to all information security regulations of the participating parties. Parties might further decide to maintain their own information on their own systems. Higher information security needs might require additional hardware and software and maintenance efforts. There are various ways to implement access controls to restrict interaction to selected participants.

In confidence building for a regional ISF, high quality, reliable, and secure technical systems can play an important role in establishing an impartial result that allows the observer to draw an independent conclusion. Past experiences in developing remote monitoring technologies not only for safeguards purposes, but for transparency are good examples. Real-time images, provided by some remote monitoring systems, allow the viewer to approximate an actual on-site experience. Remote monitoring systems that include surveillance cameras and tools for recording and analyzing the images, and other sensors that confirm the presence, mass, location and movement of nuclear material boost the viewer's confidence of what he or she sees. Video clips and photographs provide this sense of reality to a lesser degree. Also, unless pre-recorded video and photos are authenticated and encrypted, information content could be compromised by spoofing. The IAEA has implemented remote monitoring with a high degree of information security to maintain continuity of knowledge about the monitored area. Surveillance data is authenticated and encrypted, and further assurance of the status of monitored items is provided by tamper indicating seals. These systems are used for verification purposes. For the purposes of regional transparency, this same level of information security might or might not be necessary, but should be evaluated on a case by case basis.

A website or web portal established for information sharing can be set up for

different levels of access that are customized by each state. In some ISF models, the state and its organizations might control individual websites that are linked to a web portal. This could give the state more control over how the websites are accessed and by whom. A website acting as a portal or gateway to individual websites would provide links to these state-controlled websites. Some specific architectures were described in Kawakubo, et al²²⁾.

Web-based reports of near-real time measurements are also useful. JAEA worked with SNL under actions sheets “Cooperation in Nuclear Transparency” to display environmental radiation measurements from many facilities and countries on the CSCAP Nuclear Transparency website. Here, the displays were harmonized so that the look and feel was similar enough for the user to more easily absorb the information and compare the results from site to site.

Establishing video surveillance requires equipment and reliable maintenance. To minimize costs while providing information from remote monitoring systems to multiple audiences, such as the facility operator, SSAC, IAEA, and other interested parties in the information sharing framework, some components of the system could conceivably be shared. For example the camera feeds (raw video data) could be shared by separate safety, security, safeguards, and transparency systems. Data collection and transmission equipment would be controlled by users to analyze the data for their specific purposes. Also, some users, such as the IAEA, have strict requirements for information security and might not share use of its data streams even with separate data collection and analysis systems for each user.

Balancing Face-to-face and Web-based Interactions

JAEA concluded that both face-to-face and web-based information sharing are essential elements of an ISF. The positive features of face-to-face and web-based mechanisms are generally complementary and non-overlapping. Some communication requires a face-to-face setting. However, the ISF will also rely on web-based tools. Although only non-sensitive information would be shared, information security and controlled access are necessary to minimize the risk of misuse and give the user a higher level of confidence in the system.

(6) Measures of Effectiveness

The project team has discussed various ways to measure the effectiveness of the ISF. We predict that measuring the level or change in the level of trust and confidence that one state or organization has for another will be difficult to quantify regardless of the measurement approach. The first approach is to measure easily quantifiable things.

Some preliminary ideas for evaluating the model ISF are listed below.

1. Document existing information sharing exchanges as a baseline.
2. Document the number of new information sharing exchanges since the beginning of PAS-16 and AS-26 (sometime after July 2013), their outcomes and lessons learned.
3. Document the number of participants and changes in the number of users since the beginning of the demonstration.
4. Document activities and what has been done since PAS-16 and AS-26 have begun:
 - a. Project teleconferences and face-to-face meetings
 - b. Workshops
 - c. Publications and presentations
 - d. Survey (Interviews)
 - e. Development of requirements

Although the above items are a measure of activity, some conclusions about effectiveness and impact can be drawn; however, increased interaction and information sharing is not a direct measure of confidence building. It will also be necessary to interview the information sharing partners about their level of satisfaction with the information sharing experience and try to elucidate some objective conclusions from the results.

A possible approach for measuring confidence building might be derived from one proposed by C.Everton et al.²⁹⁾ for IAEA's state evaluation process, which involves finding an appropriate mix of qualitative and quantitative factors that can be used to inform an opinion about the status of a state's nuclear energy program.

The number of ISF partners and other factors will also affect how the ISF can be evaluated. If the number of partners and stakeholders is small, then informal feedback and exchange might be sufficient. With a larger group, a more formal and standardized questionnaire in addition to open discussions about benefits to participating organizations might be necessary.

A more definitive measure of effectiveness and impact of the ISF on an international scale would be to conduct a survey similar to effort of E. Kwon³⁰⁾ to measure the change in credibility of a state's nuclear program for peaceful use; however, undertaking this kind of survey must be designed and executed carefully to ensure credible results.

2.3 ISF Architectures

The survey results showed that the main information sharing interactions are between functionally similar groups. These relationships will guide the design and scope of an ISF and whether it is a single regional framework or separate ISFs established for specific nonproliferation areas, such as COEs, safeguards R&D, nuclear security and

physical protection. Within a single, regional ISF, the structure might accommodate closer interactions between functionally similar groups and looser ones among groups with different purposes. Fig. 2.1 is a schematic of some of the current information sharing relationships for APSN, FNCA, and the bilateral agreements of JAEA-US DOE and ROK NSSC- US DOE. Organizations with similar roles have a higher interest in interacting with each other, to share lessons learned, conduct R&D, etc. They are aligned horizontally across the figure. APSN and FNCA both have members from government ministries (Track 1) and SSAC and COE organizations (Track 2). Within each state, coordination for policy and national consistency occurs between ministries and governmental agencies and the organizations for which they set policies and supply funding (vertically up and down in the figure). Presumably lines of communication and protocols already exist for organizations within a state, but an ISF might also be of value. The organization and design of the ISF will take these relationships into consideration. Other stakeholders such as NGOs, academia and IAEA might interact with more than one organization within a state, depending on their own missions and objectives. Providing information for the public, business, activism, etc. is often organized by the public affairs offices and many departments have their own home pages on the parent organization's website. The decision to open the ISF to these parties will vary, depending on the stakeholder, the benefit to be gained, type of information to be shared, etc.

As more parties are added to the ISF, we might see that the relationships and the shared information vary, for example, mature nuclear fuel cycle programs might share different information with each other than they would with less mature nuclear programs.

As mentioned, another arrangement of the ISF might be completely separate ISF systems for each mission area or association. For example, APSN might have its own ISF that serves only APSN-related communication. Nuclear security interests might be better served by a separate ISF, and so on. A comprehensive ISF that involves all possible partner organizations and communication pathways might be unwieldy and unmanageable.

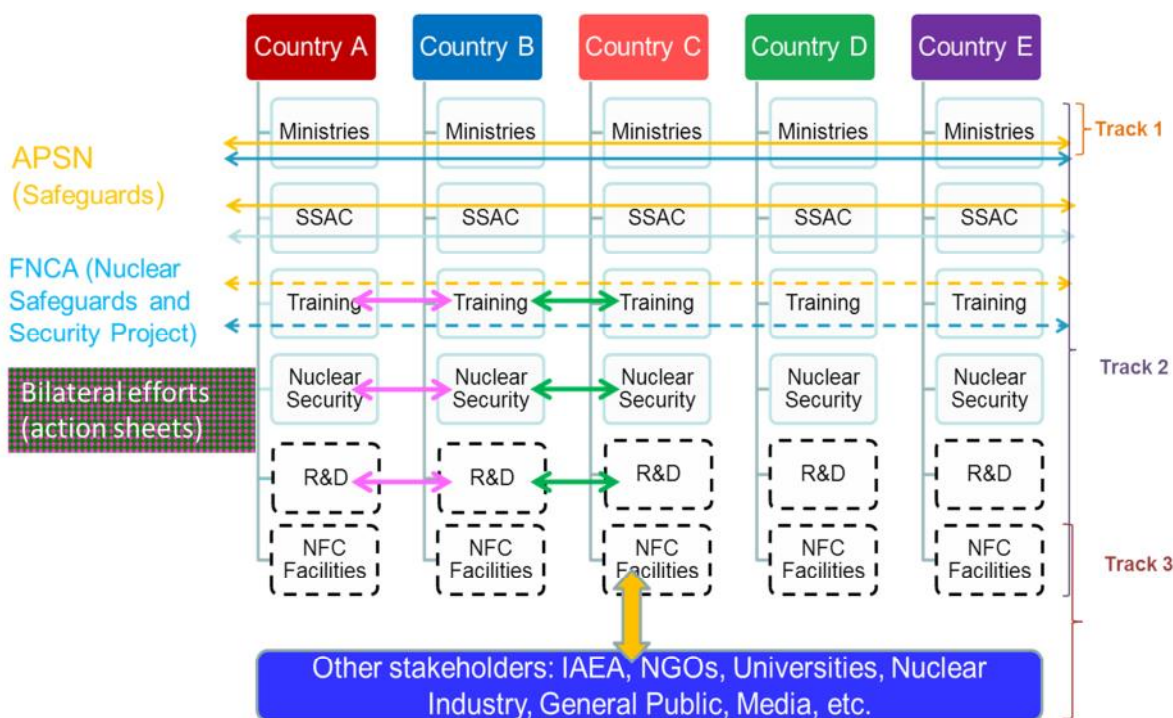

Fig. 2.1 The figure depicts an expanded ISF. Overlaid are some examples of existing information sharing relationships, such as APSN, FNCA, and bilateral efforts, such as the US DOE – JAEA and US DOE – ROK NSSC cooperation agreements.

3. Possible Outcomes

3.1 ISF for Regional Nonproliferation Cooperation

The primary focus of PAS-16 and AS-26 are to develop an ISF for regional nonproliferation cooperation. In the first workshop and through subsequent activities, participants determined that there continues to be a compelling need for countries to share information with each about their nuclear energy programs to allay concerns and to increase cooperation for mutual benefit. Ideally, all nuclear energy-related organizations in a country should be aligned with the national laws and policies so that when they interact with international counterparts, they present consistent, reinforcing and credible information, which over time, establishes a high level of confidence in the peaceful nature of the nuclear programs.

The organizations associated with PAS-16 and AS-26 are technical organizations with responsibilities for safeguards and security R&D and training and safeguards implementation design. In design of the model ISF, these organizations appropriately selected topic areas for information sharing that directly support their missions and objectives. The decision-making process of each state’s long term R&D plans in nuclear energy and nonproliferation was selected as a specific example to develop ISF requirements. The audience sharing the information would be experts at JAEA, KINAC,

KAERI, and SNL; decision makers, and sponsors of nonproliferation R&D efforts. The information should be relevant, non-sensitive nonproliferation-related information from published documents, open sources, and other documents that are authorized for sharing through the ISF. The information selected for sharing must be of interested to the audience. A list of candidate documents include: Japan Atomic Energy Commission Documents, white papers on nuclear energy in Japan, Korean nuclear energy plan/strategy abstract (if available), US publically available nuclear energy program related reports, ROK/Japan/US IAEA support program reports, executive summaries from IAEA MSSP bi-annual meetings.

Japan and Korea both have mature nuclear fuel cycle programs and many years of experience. Lessons learned from experiences of safeguards implementation, nuclear security, safeguards, and safety infrastructure and human resource development, as well as best practices are examples of rich sources of valuable information for up and coming nuclear programs.

Japan and Korea have joined an increasing number of countries with organizations and efforts to assist emerging nuclear power countries through training, provision of best practice guides, and other venues. COEs, such as JAEA's ISCN have been established and have begun holding training and expert missions in both safeguards and nuclear security topics. APSN completed a needs survey of its members and found that in addition to capabilities offered by mature nuclear program countries, some emerging nuclear power countries have extensive safeguards experiences that can be used for training²⁷⁾. The ISF could be used by APSN members and COEs on a regional basis to share information with each other, coordinate training opportunities, and to post general information for a wider audience. The outcomes of these interactions should be higher confidence in each other's programs and greater regional cooperation.

3.2 How the ISF can Support IAEA Safeguards

At the outset of the project, project partners agreed that one objective of the ISF is to be complementary to IAEA missions. The current focus of the model ISF includes nuclear safeguards and nuclear security, both of which are IAEA mission areas. The ISF goals of developing effective ways of state-to-state or state-to-other stakeholder information sharing should be consistent with IAEA information needs

In the safeguards area, experts have been discussing the current challenges to IAEA verification. IAEA must continually improve its efficiency for verifying states' declarations regarding declared facilities and activities as well as determine to the extent possible the absence of undeclared activities and facilities. J. Carlson says²⁵⁾ that the most serious challenge facing the IAEA is having the capability to detect undeclared nuclear activities. Other challenges include "the potential spread of

proliferation-sensitive technologies (enrichment and reprocessing) to further states; the implications of new fuel cycle technologies; and an ever-increasing workload.”

Through the development of the SLC, the IAEA continues to hone a systematic methodology for assessing the state as a whole. SSACs/RSACs roles have been reviewed for how they can more fully support IAEA’s efforts under the SLC. J. Cooley³¹⁾ stated that one of the strategies to strengthen cooperation and partnerships is to convince states to increase voluntary sharing of safeguards relevant information and increase cooperation and coordination within IAEA’s Member MSSP. A. Raffo-Caidao and J. Johnson also mention³²⁾ SSAC provision of information beyond the requirements of INFCIRC/153 and INFCIRC/540 including additional facility information and/or expanded declarations, and through voluntary field trials, technical cooperation, and various member state cooperation activities and meetings.

Although the above strategies might all refer to bilateral activities between the IAEA and each member state, some multilateral exchanges can be envisioned. Casterton, as the chair of SAGSI described future evolution of SSAC/IAEA Cooperation from SAGSI’s point of view³³⁾. Cooperation is viewed to be a key to increased efficiencies and effectiveness in international safeguards. He stated that enhanced cooperation with SSACs/RSACs beyond the baseline, or obligatory measures, could lead to improvements. In 2012, he advocated the formulation of a forum in which SSACs and operators could exchange best practices and lessons learned, and further emphasized the value of this exchange especially for the benefit of emerging nuclear power countries and increased cooperation between SSACs³⁴⁾. SAGSI has recommended establishing a forum organized by IAEA, INMM, WINS, or ESARDA for SSACs to exchange ideas and information. The APSN was established in 2009 with this as a goal for the Asia Pacific region. Casterton recommends an even larger participation than APSN, if possible. This increased information sharing across SSACs would enhance confidence building not only among the SSAC states, but also from the point of view of IAEA and the international community.

Casterton claims that another opportunity for increased international transparency and confidence building would be for SSACs to go beyond the obligatory requirements in their safeguards agreements with the IAEA to voluntarily release information on nuclear material and activities that can deepen IAEA’s understanding of the subject nuclear programs and to establish a record of prompt resolution of anomalies and willingness to give additional access to information. He suggests that SSACs/operators provide greater access at sites, allow for remotely observable areas, and provide specific information such as design information and R&D information.

Additional reporting would also increase confidence in peaceful use programs by establishing a reputation for openness. If states are working with IAEA to increase the

amount of information provided, or if states are working with each other to exchange information, then perhaps some of the same information can be shared to accomplish IAEA goals and improve standing among regional stakeholders so that additional efforts to meet two separate goals can be minimized. Table 3.1 summarizes some IAEA issues pairs them with potential activities to resolve them that could be conducted under an ISF.

Table 3.1 Using the ISF to Address IAEA Issues and Strategies

IAEA Issue	ISF Activity
Detect undeclared activities and facilities	Share information about national nuclear policies Share information about nuclear programs. Provide greater access to facilities, information about how material is processed and, design and R&D information. Conduct field trials, tours and other activities that increase awareness.
Spread of ENR to other countries	Share information about nuclear programs, national laws and policies that govern international nuclear trade, and related international partner arrangements.
New nuclear fuel cycles	Share information about nuclear fuel cycle research, provide greater access to facilities, design and R&D information
Increasing IAEA workload	Develop and use standard information content formats Facilitate increased technical cooperation and information exchange among Member State Support Programs (MSSP)

The ISF can help with the above issues in the following ways:

1. Development of new fuel cycles should include outreach activities to demonstrate transparency and share pertinent details about safety, safeguards, and security considerations. The ISF could be used to connect interested parties for sharing information between technical specialists. Example mechanisms include face-to-face meetings, workshops, symposia and facility tours, and web-based information exchange and virtual tours of fuel cycle research facilities, such as pyroprocessing in Korea and fast reactor technology in Japan. Information suppliers would be the fuel

cycle development organizations and sponsors. Information receivers would be relevant technical organizations in other states, NGOs that analyze open source information, and, of course, IAEA.

2. Increase the provision of SSAC voluntary information to support IAEA's independent safeguards conclusions regarding declared facilities and activities. One task of the ISF design is to develop guidelines and provide examples for defining the information content. A further step to standardize the reporting format would help to facilitate assessments and increase the provision of relevant and useful information on the receiver's end. This might be a very difficult and time-consuming to establish, but worthwhile in the long run for reducing the amount of time organizing and preparing data for analysis on the receiver's end. Moreover, the results of this effort to develop a standard format can be used by states to share information with the IAEA or with each other. Perhaps not all information can be easily packaged in a standard form, but over time, a standard approach will save time for both information suppliers and receivers. Open source analysts might have some good ideas for information formats.
3. IAEA continues to mature its state level approach and refocus its verification activities from criteria driven to objectives driven in order to shift resources to an increased emphasis on verifying the absence of undeclared facilities and activities. Some SSAC experts have also indicated that the cooperation between SSACs/RSACs and the IAEA be reviewed to determine new ways of cooperating to support IAEA's objectives without increasing the burden to SSACs and RSACs³²⁾. Sharing the process and progress of the new cooperation ideas in a broader and more open context with all SSACs might ease acceptance of the ideas by increasing the trust that all states will be treated fairly in IAEA's state level analyses.

3.3 How the ISF can Support Nuclear Security Cooperation

Experts recognize the value of recent, high level efforts through the two Nuclear Security Summits and their associated activities to bring attention to the needs to establish and strengthen regional and international nuclear security cooperation and formal frameworks to share best practices, build national capabilities and encourage a nuclear security culture [35, 7]. Regarding the path forward from the 2012 Nuclear Security Summit, Floyd and Bayer recommend governmental and non-governmental cooperation, especially by regional groups and associations, and professional organizations such as INMM³⁶⁾. They point out that unlike APSN for safeguards and ANSN and FNCA for nuclear safety, there is no equivalent effort in the Asian region for nuclear security.

The existing nuclear security regime is still largely based on voluntary, national programs that are not transparent, and a variety of national, international and ad hoc

laws, regulations and agreements. States generally consider their nuclear security practices as sensitive information and this is a sticking point for sharing information. However, some experts have proposed that many aspects of nuclear security can be shared without divulging state secrets and making nuclear material sites more vulnerable. J. Carlson points out⁷⁾ that although conventional wisdom suggests that the concept of transparency is not compatible with nuclear security practices, transparency is essential for states to build regional and international confidence that their nuclear materials are well protected from unauthorized acquisition. The benefit of doing so can increase trust among their neighbors and international society.

This nuclear security cooperation gap is an opportunity to build cooperation that will also effectively integrate across all three areas of security, safeguards, and safety. The nuclear security summits have pegged IAEA as a focal point for nuclear security information and standards, training, and workshops; however, regional efforts can provide efficiency by reducing some travel expenses and time, and more importantly, serve to build useful regional cohesion and interdependence. K. Luongo recommends³⁵⁾ establishing a comprehensive, confidence building architecture to demonstrate accountability and performance that is based on clear but flexible standards. This architecture can be supported in part by existing international conventions, agreements and ad hoc voluntary cooperative efforts. The ISF could be the starting point for developing this architecture. Organizations such as IAEA and WINS that provide standards documents, training, and organize workshops and meetings in regional and international settings may be well positioned to incorporate ISF features into existing communication structures.

4. Future Steps

PAS-16 and AS-26 participants continue to refine ISF requirements and determine useful areas of information sharing. The present efforts continue to define a model ISF for sharing safeguards information among the participating organizations and evaluate the experiences. The demonstration and evaluation of the model ISF are tentatively planned for Phase 2 of the action sheet projects.

Several challenges remain for defining the ISF requirements, structure and scope. For example, is it possible to formulate a general requirements procedure that can be universally applied or must the requirements be tailored specifically for each case? Is the ISF more effective if it is designed to accommodate a narrow range of topics or a single mission, such as safeguards implementation, or COEs in the Asia Pacific, or can it effectively serve a much broader network that embraces safety, safeguards and nuclear security topics and many types of stakeholders from all interested regional states?

As mentioned, information sharing is a natural and necessary element of bilateral

and multilateral interactions of formal and informal organizations and associations. The goals of the ISF are to enable direct, transparent sharing of information and increase confidence, trust and synergy between partners. In short, the ISF should instill and complement a “transparency culture.” To improve the chances of success and sustainability, ISF concepts and application should be promoted within existing bilateral and multilateral organizations and associations. For example, KINAC is considering the possibility of establishing a working group in APSN to discuss ISF application. Within the JAEA-US DOE cooperation agreement there are several projects in which additional information sharing could be considered. In previous sections, consideration of how the ISF could be beneficial to the IAEA, new fuel cycle research and the development of nuclear security cooperation were discussed. The IAEA’s Member (MSSP), which consists of more than 20 states engaged in various technical support areas for IAEA safeguards, is another venue of possible increased information exchange and R&D collaboration among states that could be supported by the ISF. Increased cooperation and coordination would contribute to the goals of a shared vision and increased confidence in peaceful use programs.

5. Conclusions

Under the current project, JAEA, SNL, KINAC and KAERI are developing requirements for an ISF that can be used for further regional cooperation and thereby increase trust and confidence building, improve cooperation with the IAEA. Project partners have explored and analyzed the compelling need for transparency, candidate information sharing topics, needs of stakeholders for a model framework, communication modes, possible ISF architectures, information security issues, and various future applications of an ISF. The project has drafted ISF requirements using the continuous improvement model of “Plan, Do, Check and Adjust” to focus attention on identifying, executing and continuously improving an information sharing structure. Activities of the project itself have been exercises in transparency; partners have engaged face-to-face in workshops, meetings and tours, and web-based through email and the development of a content management website for posting project information. Monthly teleconferences have helped to maintain project focus and meet deadlines.

The need for transparency in a regional setting has been expressed by many experts and confirmed through this project’s activities. In the Asia Pacific area, in particular, where there is a diverse mix of mature and developing nuclear programs, transparency is important for reducing regional tension that arises from uncertainty and lack of understanding regarding nuclear program activities in neighboring countries. By actively sharing information and expertise, countries can also reduce concerns and help each country move closer to its nuclear energy goals. Mature nuclear states have the

expertise to support infrastructure development in less mature states and many are already assisting them or developing programs to do so. Also, mature nuclear states working together have developed and implemented many useful technological solutions for nonproliferation applications.

Transparency is a necessary element for successful bilateral and multilateral activities. The survey of stakeholders for the model ISF design conducted by project partners demonstrated that much information sharing is conducted in order to meet organizational performance goals and that transparency is a by-product of that process. This factor should be a motivating force in encouraging more regional cooperation and coordination because the “cost” of transparency does not have to be considered an additional expense.

Furthermore, technical organizations, such as JAEA, SNL, KINAC and KAERI, working bilaterally or multilaterally, put national nonproliferation policies into practice through development and implementation of safeguards and nuclear security systems. These systems are tangible proof of a country’s policies that are visible not only to the participating partners, but also the international community. Technical cooperation also requires partners to share information to achieve performance goals, and transparency is therefore carried out as part of routine activities. The ISF can further support these activities by providing a process to clearly and efficiently identify useful information to share, and determine how to share it and protect it, and evaluate and improve the effectiveness of the information sharing.

PAS-16 studies have confirmed the importance of both face-to-face and web-based information sharing practices. Face-to-face activities are more effective at establishing and reinforcing personal relationships that need time to develop in order to build trust and confidence in the peaceful nature of a country’s nuclear programs. Web-based information sharing tools can provide useful documents, images, and videos that enhance and reinforce the face-to-face encounters and are a convenient way to maintain connections when travel funding and schedules are limited.

Formal and informal agreements that establish organizations and cooperative arrangements are instrumental in ensuring sustainable information sharing. Notable examples are ABACC and ESARDA. Under the JAEA and US DOE/NNSA cooperation agreement, established in 1988, transparency has been a by-product of many nonproliferation R&D projects, which include the work of JAEA and SNL for 20 years to develop and demonstrate transparency concepts for regional confidence building and safeguards applications. Transparency has also been a hallmark of US DOE bilateral cooperation agreements and many multilateral associations. In the Asia Pacific region, voluntary networks, such as APSN and FNCA, and now the trilateral association of JAEA, KINAC and KAERI, and SNL are practicing information sharing in the context of

achieving organizational goals, or, as in the case of the latter group, to develop and test information sharing concepts, processes and structures.

Future applications of the ISF have been considered, including voluntary efforts to facilitate information sharing for improving safeguards implementation in the Asia Pacific (e.g., APSN), coordination of COEs, reducing concerns about advanced nuclear fuel cycle development, and improving nuclear security practices.

The next steps for the ISF include continued refinement of requirements, selection of test information sharing cases, and design and execution of the ISF tests and evaluation.

References

- 1) S. Ogawa and M. Schiffer, "Japan's Plutonium Reprocessing Dilemma," Arms Control Today, available from <http://www.armscontrol.org/print/1901>, 2005.
- 2) C. Harmon, J. Olsen and H. Passell, "Nuclear Facility Transparency: Definition and Concepts," Cooperative Monitoring Center, Sandia National Laboratories <http://www.cmc.sandia.gov/cmc-papers/usjapanoct2000.pdf>, 2000.
- 3) Economist Intelligence Unit, "Energy Realities", Available from: <http://www.energyrealities.org/detail/aftershocks-nuclear-power-in-asia-after-fukushima/erp84E84CC934C138AC8>. [Accessed 10 January 2013].
- 4) Asia Pacific Safeguards Network, Available from <http://www.apsn-safeguards.org/>
- 5) Council for Security Cooperation in the Asia Pacific, Available from <http://www.cscap.org/index.php?page=countering-the-proliferation-of-weapons-of-mass-destruction-in-the-asia-pacific>.
- 6) Nuclear Security Summit, "Seoul Communiqué," 2012. [Online]. Available: http://www.thenuclearsecuritysummit.org/userfiles/Seoul%20Communique_FINAL.pdf. [Accessed 10 January 2013].
- 7) J. Carlson, "Transparency, Accountability and Assurance in Nuclear Security," <http://www.nti.org/analysis/articles/transparency-accountability-and-assurance-nuclear-security>, 2012.
- 8) O. Peixoto, "ABACC – Safeguards & Transparency", Seoul: 4th Int'l Nuclear Nonproliferation and Security Symposium, 2012.
- 9) European Safeguards Research and Development Association, "European Treaty Factsheet". Available from: http://esarda2.jrc.it/references/Technical_sheets/ts-EURATOM-040304.pdf.
- 10) K. Choe, "Prospective of Regional Safeguards Cooperation in Connection with the Asia-Pacific Safeguards Network (APSN)," in Proc. Institute for Nuclear Material Management Annual Meeting, Orlando, 2012.

- 11) Forum for Nuclear Cooperation in Asia, Japan Ministry for Education, Culture, Sports, Science & Technology, Available from: <http://www.fnca.mext.go.jp/english/>. [Accessed 10 January 2013].
- 12) Forum for Nuclear Cooperation in Asia, Nuclear Safeguards and Security Project, Available from: http://www.fnca.mext.go.jp/english/nss/e_ws_2011.html. [Accessed 10 January 2013].
- 13) N. Inoue Nakashima, J. Olsen, K. E. D. Horak, R. Cossa and B. Glosserman, "A Regional Web Site for Nuclear Transparency in the Asia Pacific," in Proc. of the Institute for Nuclear Material Management Annual Meeting , 2002.
- 14) A. Heyes, "An Assessment of the Nuclear Security Centers of Excellence," Policy Analysis Brief The Stanley Foundation," May 2012, Available from: <http://www.stanleyfoundation.org/publications/pab/AlanHeyesPAB512.pdf>. [Accessed 10 January 2013].
- 15) R. R. Speier and B. Chow, "Asiatom: Proposals, Alternatives and Next Steps," RAND, DRU-1367-DOE, July 1997.
- 16) J. Furaus, M. Hori and D. Glidewell, "Development and Evaluation of a Program of Regional Collaboration for Non-Proliferation and Transparency," Available from http://esarda2.jrc.it/db_proceeding/mfile/P_2003_Stockholm_026-a-furaus-030716.pdf, 2003.
- 17) M. Nam and S. Shin, "ENTNEA: A Concept for Enhancing Nuclear Transparency for Confidence Building in Northeast Asia, SAND 98-0505/12," June 1999. [Online]. Available: <http://www.cmc.sandia.gov/issues/papers/entnea/index.html>.
- 18) "Agreement between JAEA and the DOE for Cooperation in Research and Development Concerning Nuclear Material Control and Accounting Measures for Safeguards and Nonproliferation," Available from: http://www.jaea.go.jp/04/np/etc/2006-07-21/index_en.html . [Accessed 10 January 2013].
- 19) J. Olsen, M. Hori, Y. Hashimoto, N. Inoue, J. Furaus, S. Caskey and R. Lucero, "Regional Cooperation in Remote Monitoring for Nuclear Nonproliferation and Transparency," in Proc. Institute for Nuclear Material Management Annual Meeting, 2005.
- 20) J. Olsen, "Activities to Further Nonproliferation and Encourage Confidence Building Measures on the Korean Peninsula", Available from: <http://www.cmc.sandia.gov/cmc-papers/korea.pdf>. [Accessed 10 January 2013].
- 21) R. Mongiello, G. Baldwin, B. Hoffheins, N. Inoue and Y. Kawakubo, "Development of an Information Sharing Framework: Efforts at Regional Transparency in the Asia Pacific," in Proc. Institute for Nuclear Material Management Annual Meeting, Orlando, 2012.
- 22) Y. Kawakubo, B. Hoffheins, N. Inoue, R. Mongiello and G. Baldwin, "Development of

- an Information Sharing Framework: Communication Strategies," in Proc. Institute for Nuclear Material Management Annual Meeting, Orlando, 2012.
- 23) United States Department of Energy, National Nuclear Security Administration, "Japan Nuclear Security Working Group Fact Sheet," 27 March 2012. Available from: <http://nnsa.energy.gov/mediaroom/factsheets/usjapanworking>. [Accessed 10 January 2013].
- 24) G. Baldwin and R. Mongiello, "Structuring the Nuclear Nonproliferation Transparency Problem," in Proc. Institute for Nuclear Material Management Annual Meeting, Orlando, 2012.
- 25) J. Carlson, "New Verification Challenges," J. Nuclear Materials Management, vol. XXXVII, no. 4, Summer 2009.
- 26) Nuclear Regulation Authority, "Leaflet,". Available from: http://www.nsr.go.jp/english/e_nra/leaflet/data/nsr_leaflet_English.pdf. [Accessed 10 January 2013].
- 27) Asia Pacific Safeguards Network, "Asia-Pacific Safeguards Network Survey: Report of Findings," December 2011. Available from: http://www.apsn-safeguards.org/pdfs/APSNDDecember_2011_Forgeneralrelease.pdf. [Accessed 10 January 2013].
- 28) M. Rhoads, "Face-to-Face and Computer-Mediated Communication: What Does Theory Tell Us and What Have We Learned so Far?," J. Planning Literature, vol. 25, no. <http://jpl.sagepub.com/content/25/2/111.full.pdf+html>, 2010.
- 29) C. Everton, R. Leslie, S. Bayer and M. East, "Transparency and other State-Specific Factors: Exploration of Ideas for Evolving the IAEA's System of State-Evaluations and Safeguards Implementation," ESARDA Bulletin, vol. 46, 2011.
- 30) E. Kwon, "A Quantitative Evaluation of States' Nuclear Nonproliferation Credibility," in Proc. Institute for Nuclear Material Management Annual Meeting, Orlando, 2012.
- 31) J. Cooley, "International Forum on Peaceful Use of Nuclear Energy and Nuclear Non-Proliferation - IAEA Efforts for Further Enhancing the Effectiveness and Efficiency of IAEA Safeguards," February 2011. Available from: <http://www.jaea.go.jp/04/np/activity/2011-02-02/2011-02-02-04.pdf>.
- 32) A. Raffo-Caidao and J. Johnson, "Cooperation between SSACs/RSACs and the IAEA under the State-Level Concept: An Evolving Process," in Proc. Institute for Nuclear Material Management Annual Meeting, Orlando, 2012.
- 33) J. Casterton, "The Further Evolution of SSAC/IAEA Cooperation: SAGSI's Considerations," in Proc. Symposium on International Safeguards: Preparing for Future Safeguards Challenges IAEA-CN-184/218, Vienna, 2010.
- 34) J. Casterton and e. al., "SSAC/IAEA Cooperation: Some Reflections from the Canadian SSAC," in Proc. Institute for Nuclear Material Management Annual Meeting,

Orlando, 2012.

35) K. Luongo, "Nuclear Security Governance for the 21st Century: Assessment and Action Plan, US-Korea Institute Working Paper," March 2012. Available from: <http://uskoreainstitute.org/?s=luong>. [Accessed 11 January 2013].

36) R. Floyd and S. Bayer, "Nuclear Security Summit: 2014 and Beyond," in Proc. Institute for Nuclear Material Management Annual Meeting, Orlando, 2012.

37) T. Kassenova, "A Regional Approach to WMD Nonproliferation in the Asia-Pacific," Carnegie Endowment for International Peace, Policy Outlook http://www.carnegieendowment.org/files/asia_wmd.pdf, 2012.

38) R. Arvey, "International Association of Conference Centers - Why Face-to-Face Business Meetings Matter". Available from: <http://www.iacconline.org/content/files/WhyFace-to-FaceBusinessMeetingsMatter.pdf>. [Accessed 10 January 2013].

This is a blank page.

国際単位系 (SI)

表1. SI基本単位

基本量	SI基本単位	
	名称	記号
長さ	メートル	m
質量	キログラム	kg
時間	秒	s
電流	アンペア	A
熱力学温度	ケルビン	K
物質の量	モル	mol
光度	カンデラ	cd

表2. 基本単位を用いて表されるSI組立単位の例

組立量	SI基本単位	
	名称	記号
面積	平方メートル	m ²
体積	立法メートル	m ³
速度	メートル毎秒	m/s
加速度	メートル毎秒毎秒	m/s ²
波数	毎メートル	m ⁻¹
密度, 質量密度	キログラム毎立方メートル	kg/m ³
面積密度	キログラム毎平方メートル	kg/m ²
比体積	立方メートル毎キログラム	m ³ /kg
電流密度	アンペア毎平方メートル	A/m ²
磁界の強さ	アンペア毎メートル	A/m
量濃度 ^(a) , 濃度	モル毎立方メートル	mol/m ³
質量濃度	キログラム毎立方メートル	kg/m ³
輝度	カンデラ毎平方メートル	cd/m ²
屈折率 ^(b)	(数字の)	1
比透磁率 ^(b)	(数字の)	1

(a) 量濃度 (amount concentration) は臨床化学の分野では物質濃度 (substance concentration) ともよばれる。
 (b) これらは無次元量あるいは次元1をもつ量であるが、そのことを表す単位記号である数字の1は通常は表記しない。

表3. 固有の名称と記号で表されるSI組立単位

組立量	SI組立単位		
	名称	記号	他のSI単位による表し方
平面角	ラジアン ^(b)	rad	1 ^(b)
立体角	ステラジアン ^(b)	sr ^(c)	1 ^(b)
周波数	ヘルツ ^(d)	Hz	s ⁻¹
力	ニュートン	N	m kg s ⁻²
圧力, 応力	パスカル	Pa	N/m ²
エネルギー, 仕事, 熱量	ジュール	J	N m
仕事率, 工率, 放射束	ワット	W	J/s
電荷, 電気量	クーロン	C	s A
電位差 (電圧), 起電力	ボルト	V	W/A
静電容量	ファラド	F	C/V
電気抵抗	オーム	Ω	V/A
コンダクタンス	ジーメン	S	A/V
磁束	ウェーバ	Wb	Vs
磁束密度	テスラ	T	Wb/m ²
インダクタンス	ヘンリー	H	Wb/A
セルシウス温度	セルシウス度 ^(e)	°C	K
光照射度	ルーメン	lm	cd sr ^(c)
放射線量	グレイ	Gy	J/kg
放射性核種の放射能 ^(f)	ベクレル ^(d)	Bq	s ⁻¹
吸収線量, 比エネルギー分与, カーマ	グレイ	Gy	J/kg
線量当量, 周辺線量当量, 方向性線量当量, 個人線量当量	シーベルト ^(g)	Sv	J/kg
酸素活性化	カタール	kat	s ⁻¹ mol

(a) SI接頭語は固有の名称と記号を持つ組立単位と組み合わせても使用できる。しかし接頭語を付した単位はもはやコヒーレントではない。
 (b) ラジアンとステラジアンは数字の1に対する単位の特別な名称で、量についての情報をつたえるために使われる。実際には、使用する時には記号rad及びsrが用いられるが、習慣として組立単位としての記号である数字の1は明示されない。
 (c) 測光学ではステラジアンという名称と記号srを単位の表し方の中に、そのまま維持している。
 (d) ヘルツは周期現象についてのみ、ベクレルは放射性核種の統計的過程についてのみ使用される。
 (e) セルシウス度はケルビンの特別な名称で、セルシウス温度を表すために使用される。セルシウス度とケルビンの単位の大きさは同一である。したがって、温度差や温度間隔を表す数値はどちらの単位で表しても同じである。
 (f) 放射性核種の放射能 (activity referred to a radionuclide) は、しばしば誤った用語で"radioactivity"と記される。
 (g) 単位シーベルト (PV.2002.70,205) についてはCIPM勧告2 (CI-2002) を参照。

表4. 単位の中に固有の名称と記号を含むSI組立単位の例

組立量	SI組立単位	
	名称	記号
粘力のモーメント	パスカル秒	Pa s
表面張力	ニュートンメートル	N m
角加速度	ラジアン毎秒	rad/s
角加減	ラジアン毎秒毎秒	rad/s ²
熱流密度, 放射照度	ワット毎平方メートル	W/m ²
熱容量, エントロピー	ジュール毎ケルビン	J/K
比熱容量, 比エントロピー	ジュール毎キログラム毎ケルビン	J/(kg K)
比エネルギー	ジュール毎キログラム	J/kg
熱伝導率	ワット毎メートル毎ケルビン	W/(m K)
体積エネルギー	ジュール毎立方メートル	J/m ³
電界の強さ	ボルト毎メートル	V/m
電荷密度	クーロン毎立方メートル	C/m ³
電表面電荷	クーロン毎平方メートル	C/m ²
電束密度, 電気変位	クーロン毎平方メートル	C/m ²
誘電率	ファラド毎メートル	F/m
透磁率	ヘンリー毎メートル	H/m
モルエネルギー	ジュール毎モル	J/mol
モルエントロピー, モル熱容量	ジュール毎モル毎ケルビン	J/(mol K)
照射線量 (X線及びγ線)	クーロン毎キログラム	C/kg
吸収線量率	グレイ毎秒	Gy/s
放射線強度	ワット毎ステラジアン	W/sr
放射輝度	ワット毎平方メートル毎ステラジアン	W/(m ² sr)
酵素活性濃度	カタール毎立方メートル	kat/m ³

表5. SI接頭語

乗数	接頭語	記号	乗数	接頭語	記号
10 ²⁴	ヨタ	Y	10 ¹	デシ	d
10 ²¹	ゼタ	Z	10 ²	センチ	c
10 ¹⁸	エクサ	E	10 ³	ミリ	m
10 ¹⁵	ペタ	P	10 ⁶	マイクロ	μ
10 ¹²	テラ	T	10 ⁹	ナノ	n
10 ⁹	ギガ	G	10 ¹²	ピコ	p
10 ⁶	メガ	M	10 ⁻¹⁵	フェムト	f
10 ³	キロ	k	10 ⁻¹⁸	アト	a
10 ²	ヘクト	h	10 ⁻²¹	ゼプト	z
10 ¹	デカ	da	10 ⁻²⁴	ヨクト	y

表6. SIに属さないが、SIと併用される単位

名称	記号	SI単位による値
分	min	1 min=60s
時	h	1 h=60 min=3600 s
日	d	1 d=24 h=86 400 s
度	°	1°=(π/180) rad
分	'	1'=(1/60)°=(π/10800) rad
秒	"	1"=(1/60)'=(π/648000) rad
ヘクタール	ha	1 ha=1 hm ² =10 ⁴ m ²
リットル	L, l	1 L=1 dm ³ =10 ³ cm ³ =10 ⁻³ m ³
トン	t	1 t=10 ³ kg

表7. SIに属さないが、SIと併用される単位で、SI単位で表される数値が実験的に得られるもの

名称	記号	SI単位で表される数値
電子ボルト	eV	1 eV=1.602 176 53(14)×10 ⁻¹⁹ J
ダルトン	Da	1 Da=1.660 538 86(28)×10 ⁻²⁷ kg
統一原子質量単位	u	1 u=1 Da
天文単位	ua	1 ua=1.495 978 706 91(6)×10 ¹¹ m

表8. SIに属さないが、SIと併用されるその他の単位

名称	記号	SI単位で表される数値
バール	bar	1 bar=0.1 MPa=100 kPa=10 ⁵ Pa
水銀柱ミリメートル	mmHg	1 mmHg=133.322 Pa
オングストローム	Å	1 Å=0.1 nm=100 pm=10 ⁻¹⁰ m
海里	M	1 M=1852 m
バイン	b	1 b=100 fm ² =(10 ¹² cm) ² =10 ⁻²⁸ m ²
ノット	kn	1 kn=(1852/3600) m/s
ネーパ	Np	SI単位との数値的関係は、 対数量の定義に依存。
ベール	B	
デジベル	dB	

表9. 固有の名称をもつCGS組立単位

名称	記号	SI単位で表される数値
エル	erg	1 erg=10 ⁻⁷ J
ダイン	dyn	1 dyn=10 ⁻⁵ N
ポアズ	P	1 P=1 dyn s cm ⁻² =0.1 Pa s
ストークス	St	1 St=1 cm ² s ⁻¹ =10 ⁻⁴ m ² s ⁻¹
スチルブ	sb	1 sb=1 cd cm ⁻² =10 ⁴ cd m ⁻²
フオト	ph	1 ph=1 cd sr cm ⁻² 10 ⁴ lx
ガリ	Gal	1 Gal=1 cm s ⁻² =10 ⁻² ms ⁻²
マクスウェル	Mx	1 Mx=1 G cm ² =10 ⁻⁸ Wb
ガウス	G	1 G=1 Mx cm ⁻² =10 ⁻⁴ T
エルステッド ^(c)	Oe	1 Oe _e =(10 ³ /4π) A m ⁻¹

(c) 3元系のCGS単位系とSIでは直接比較できないため、等号「△」は対応関係を示すものである。

表10. SIに属さないその他の単位の例

名称	記号	SI単位で表される数値
キュリー	Ci	1 Ci=3.7×10 ¹⁰ Bq
レントゲン	R	1 R=2.58×10 ⁻⁴ C/kg
ラド	rad	1 rad=1 cGy=10 ⁻² Gy
レム	rem	1 rem=1 cSv=10 ⁻² Sv
ガンマ	γ	1 γ=1 nT=10 ⁻⁹ T
フェルミ	f	1 フェルミ=1 fm=10 ⁻¹⁵ m
メートル系カラット		1メートル系カラット=200 mg=2×10 ⁻⁴ kg
トル	Torr	1 Torr=(101 325/760) Pa
標準大気圧	atm	1 atm=101 325 Pa
カロリ	cal	1 cal=4.1858 J (「15°C」カロリ), 4.1868 J (「IT」カロリ), 4.184 J (「熱化学」カロリ)
マイクロン	μ	1 μ=1 μm=10 ⁻⁶ m

